

**CITY OF WEST DES MOINES
STAFF REPORT COMMUNICATION**

Meeting Date: April 22, 2024

ITEM: Arcadia Building Amenities, 7000 Vista Drive – Approve Level 2 Minor Modification to Site Plan to allow the removal of parking and install grass, trees and shrubs, trails, a vestibule, and a pickleball court – Dallas County Partners II, – MML2-006350-2024

Resolution: Approval of Level 2 Minor Modification to Site Plan

Background: Dallas County Partners II, property owner, requests approval of the Level 2 Minor Modification to Site Plan for the approximately 34.25-acre property located at 7000 Vista Drive. The applicant proposes to replace 554 parking stalls with grass, trails, trees, shrubs, a pickleball court and add a vestibule to the entrance of the building. This minor modification to an approved site plan normally would be subject to administrative approval; however, neighboring residents have inquired into the pickleball court and have expressed concern about noise. Therefore, Staff requests review of the location of the pickleball court by the Planning and Zoning Commission and City Council. (See Key Development Aspects, bullet #1 section below for details on the pickleball court and neighboring resident's concerns).

Staff Review & Comment:

- **Financial Impact:** No City funding of the project. Staff time for processing of development application and inspections during construction.
- **Key Development Aspects:**
 1. Pickleball Court: As part of the initial Minor Modification site plan submittal, the pickleball area with two courts were shown tucked into an area towards the southeastern portion of the proposed greenspace (see enclosed illustration). Staff requested that the courts be moved further north away from the residential dwelling units to the south and the property owner agreed. The new location provides an approximate 300-foot separation from the dwelling units to the south and over 900 feet away from dwellings to the east over an intervening property.

Garry Pshonik, a resident in the single-family area to the east of the location of the improvement, has provided three pieces of information regarding the proposed courts. All three pieces of information, an email thread between Mr. Pshonik and the Lead Case Planner, a communication from Mr. Pshonik, and an ordinance and assessment report for the City of Centennial, Colorado are included within this staff report. Communication from "waisty", the word from the email address, was received as well; a copy of that communication is included as well.

The applicant, Dallas County Partners II provided the following information in an email response to another interested resident who lives in the single-family development to the east:

- The pickleball courts will be for the sole use of the tenants of the Country Club Office Plaza, which includes other buildings which RR Realty owns or manages. Signage to that affect will be posted.
- Time of operation will be from morning to 10 p.m.; property management will be observing the usage, which will likely include video monitoring.
- Trees will be planted on the south side of the court, along with the established trees on the property boundaries.

- Users will be bringing their own equipment or equipment provided by the respective tenant.

Staff supports the revised location of the courts for the following reasons:

- Seven (7) West Des Moines parks have pickleball opportunities, all are in residential areas and are open 6 a.m. to 10 p.m.
- The property owner is placing evergreen trees on the southeast side of the courts for sound mitigation and several other trees are within the project area. There are existing buffers along the residential areas.
- The City has no specific regulations regarding separation of sports related courts from property boundaries or allowed hours of use.
- A review of the City's ordinance, (Title 4 Health and Safety Regulations, Chapter 7 Noise Control), did not indicate a violation as nonprofessional athletic activities are exempt from most provisions.
- A minimum 300 feet separation is consistent with the separation distance that the city uses for outdoor activity areas associated with restaurants and bars.

2. Parking: the approved site plan for the office building provided the required 1,022 parking spaces and an additional 800 parking spaces. Today's City Code requires 991 spaces. This application proposes to remove approximately 554 parking spaces and return the area to open space while still providing more than the minimum number of parking stalls required.

- Development & Planning Subcommittee: The Minor Modification Level 2 was listed on the April 1, 2024, Development and Planning City Council Subcommittee agenda. As the project complies with all applicable zoning regulations, no discussion of the project occurred.
- Vesting of Entitlement: Per City Code, entitlement (approval to construct or implement) shall remain in effect so long as substantial site work has progressed beyond grading and completion of structural foundations and twenty-five percent (25%) of the total building area has occurred above grade within twenty-four (24) months of the effective date of the approval, unless a greater time period is authorized at time of the original entitlement, or by approval of an extension of the original entitlement. It is the responsibility of the developer to be aware of this deadline and request an extension of the approval prior to the expiration date.

Outstanding Issues: There are no outstanding issues.

Planning and Zoning Commission Action:

Date: April 22, 2024

Vote:

Recommendation:

Recommendation: Approve the Level 2 Minor Modification to Site Plan request, subject to the applicant meeting all City Code requirements.

Lead Staff Member: Kara Tragesser

Approval Meeting Dates:

Planning and Zoning Commission	April 22, 2024
City Council	

Staff Report Reviews:

Planning & Zoning Commission	<input checked="" type="checkbox"/> Development Coordinator (or) <input type="checkbox"/> Director	<input checked="" type="checkbox"/> Legal Department
City Council	<input type="checkbox"/> Director <input type="checkbox"/> Appropriations/Finance	<input type="checkbox"/> Legal Department <input type="checkbox"/> Agenda Acceptance

Publications (if applicable)

Published In:	Des Moines Register Community Section
Date(s) Published	n/a
Date(s) of Mailed Notices	n/a

Council Subcommittee Review (if applicable)

Subcommittee	Development & Planning
Date Reviewed	April 1, 2024
Recommendation	<input type="checkbox"/> Yes <input type="checkbox"/> No <input type="checkbox"/> Split <input checked="" type="checkbox"/> No Discussion

Location Map

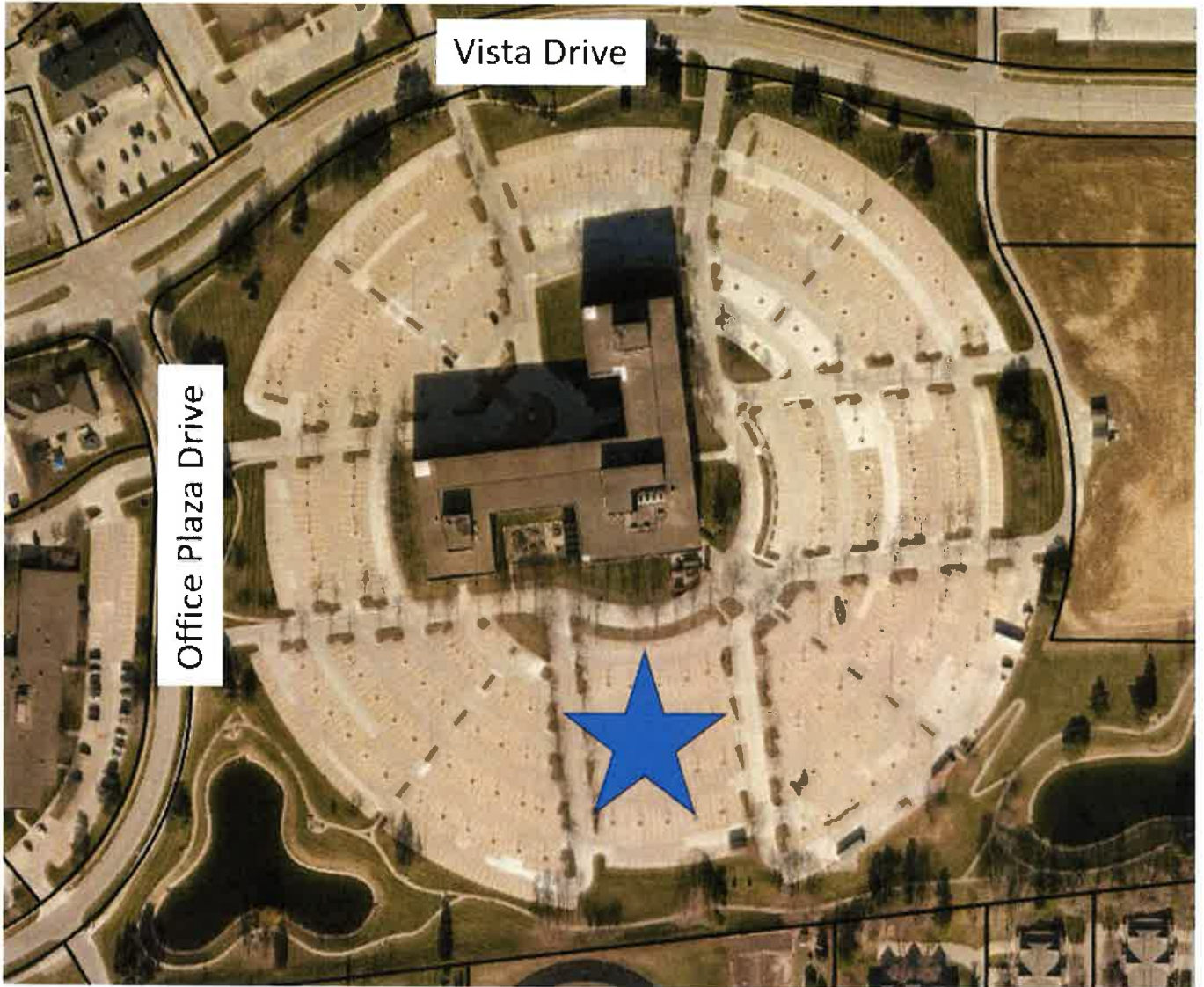

Vicinity Map – Land Uses



Approximate Distance to Residential Land Use Illustration

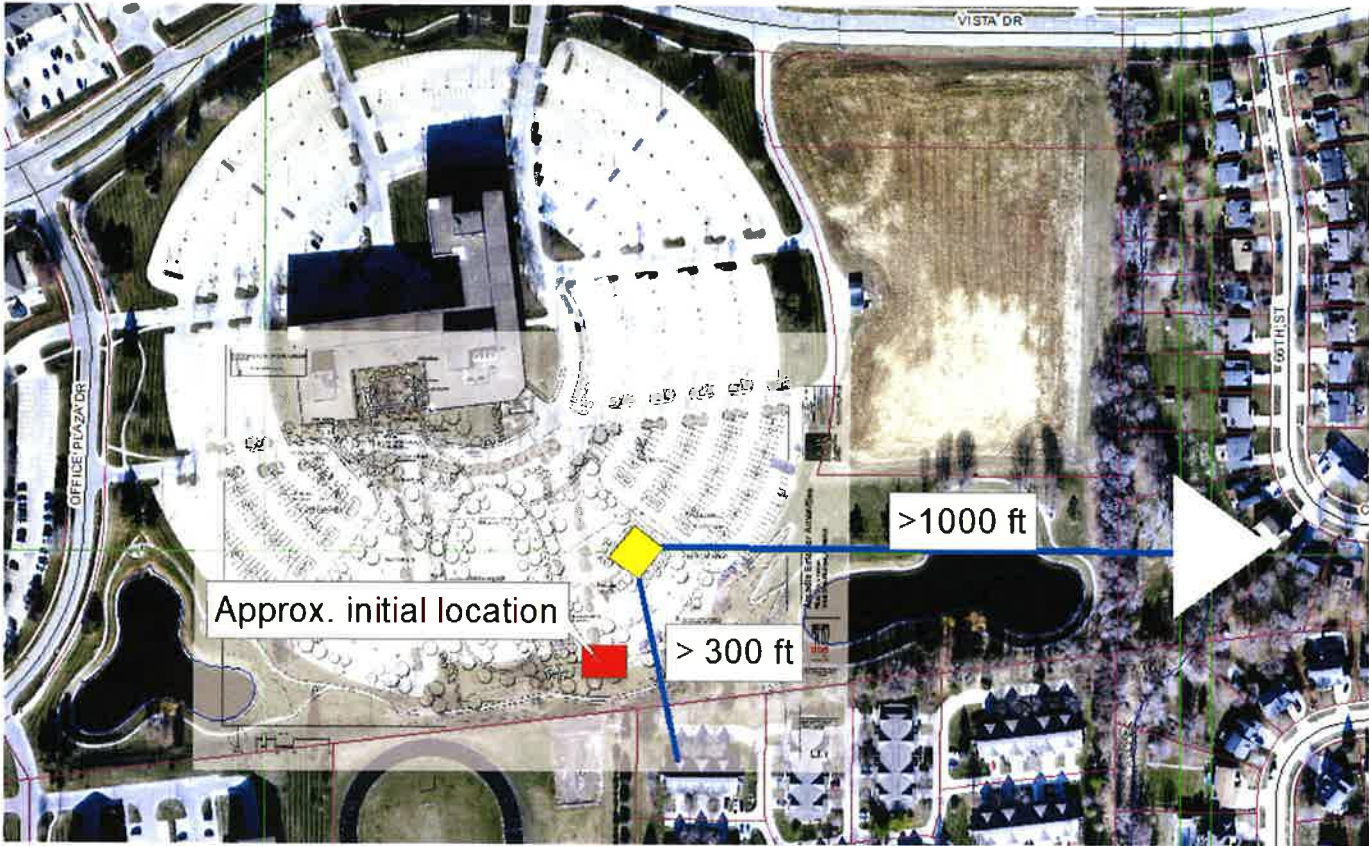

A RESOLUTION OF THE PLANNING AND ZONING COMMISSION
NO. PZC-24-016

WHEREAS, pursuant to the provisions of Title 9, Zoning of the West Des Moines Municipal Code, Dallas County Partners II, property owner, requests approval of the Level 2 Minor Modification to Site Plan for the 34.25-acre property located at 7000 Vista Drive as depicted on the location map included in the staff report. The applicant requests approval to remove parking and add grass, trees and shrubs, trails, a vestibule, and a pickleball court; and

WHEREAS, the Level 2 Minor Modification to Site Plan request complies with the findings stated in the applicable provisions of Title 9, the Comprehensive Plan and City Code.

NOW THEREFORE, the Planning and Zoning Commission of the City of West Des Moines recommends the City Council approve the Level 2 Minor Modification to Site Plan (MML2-006350-2024), subject to compliance with all the conditions of approval as stated in the staff report, including conditions added at the meeting, and attached hereto as Exhibit "A", if applicable.

PASSED AND ADOPTED on April 22, 2024.

Tina Shaw, Chair
Planning and Zoning Commission

I HEREBY CERTIFY that the foregoing resolution was duly adopted by the Planning and Zoning Commission of the City of West Des Moines, Iowa, at a regular meeting on April 22, 2024, by the following vote:

AYES:
NAYS:
ABSTENTIONS:
ABSENT:

ATTEST:

Recording Secretary



Garry Pshonik <gpshonik@gmail.com>

RE: [EXT] Proposed Arcadia Building Pickleball Courts

1 message

Kara Tragesser <Kara.Tragesser@wdm.iowa.gov>
To: Garry Pshonik <gpshonik@gmail.com>

Tue, Apr 9, 2024 at 5:34 PM

Hello,

I have discussed your concern with my supervisor and the department director. We will schedule the application to go before the Plan & Zoning Commission and City Council where you will have the opportunity to bring your concern to the Commission and attend the Council meeting.

The Commission meeting will be on Monday, April 22nd starting at 5:30p at West Des Moines City Hall. The Council meeting will be May 6th starting at 5:30p at West Des Moines City Hall.

If you have anything written that you would like the Commission and Council to read, please provide that to me by April 16, next Tuesday, for inclusion in my report. Email works just fine for this.

I look forward to meeting you on the 22nd.

Kara

From: Garry Pshonik <gpshonik@gmail.com>
Sent: Tuesday, April 9, 2024 1:13 PM
To: Kara Tragesser <Kara.Tragesser@wdm.iowa.gov>
Subject: Re: [EXT] Proposed Arcadia Building Pickleball Courts

Hi Kara,

Thank you for the updated information. It looks to me like this is only a minor adjustment from the original plan, and doesn't substantively address the noise nuisance concerns to the south and east residential areas. Would it be unreasonable to request a noise impact assessment study? Are there any avenues left to request that these plans for the pickleball courts be reevaluated?

Thank you,

Garry

On Tue, Apr 9, 2024 at 12:49 PM Kara Tragesser <Kara.Tragesser@wdm.iowa.gov> wrote:

Hello Garry,

I've attached an excerpt from the site plan set for the changes at the Arcadia Building.

They have moved the courts north and I've requested some evergreen buffer along the south side of the courts.

This plan is supported by staff. The site plan for these changes is subject to administrative review.

Its not approved yet, there is other information needed from them for erosion control before it gets approved.

Thank you for contacting me.

Kara

From: Garry Pshonik <gpshonik@gmail.com>
Sent: Monday, April 8, 2024 9:39 AM
To: Kara Tragesser <Kara.Tragesser@wdm.iowa.gov>
Subject: Re: [EXT] Proposed Arcadia Building Pickleball Courts

Hi Kara,

Just following up to ask if you have heard back from R&R regarding your comment and see what the status of things are at this point.

Thank you,

Garry Pshonik

On Tue, Mar 5, 2024 at 10:41 AM Kara Tragesser <Kara.Tragesser@wdm.iowa.gov> wrote:

Yes, I need to wait for their resubmittal to see if they took up my comment. If they did take up the comment, I don't have any idea when they will resubmit. I'll try to remember to let you know and perhaps I can share the submittal,.

Kara -

From: Garry Pshonik <gpshonik@gmail.com>
Sent: Tuesday, March 5, 2024 10:28 AM
To: Kara Tragesser <Kara.Tragesser@wdm.iowa.gov>
Subject: Re: [EXT] Proposed Arcadia Building Pickleball Courts

No no! So at this point do we just wait for RR to formally respond? When would it be appropriate for me to follow up with you next?

Thank you again for all your help!

On Tue, Mar 5, 2024 at 10:19 AM Kara Tragesser <Kara.Tragesser@wdm.iowa.gov> wrote:

Yes, RR has submitted a modification to their parking lot and, despite my warning, have shown a pickleball court on the south side.

I've already commented officially to move the court closer to the building, away from the townhomes and the apartments.

This application is subject to administrative approval. If they disagree with my comment, I can take it to the Plan & Zoning Commission and City Council if needed.

We'll see what their response is.

Kara -

From: Garry Pshonik <gpshonik@gmail.com>
Sent: Tuesday, March 5, 2024 10:14 AM
To: Kara Tragesser <Kara.Tragesser@wdm.iowa.gov>
Subject: Re: [EXT] Proposed Arcadia Building Pickleball Courts

Hi Kara,

Just touching base again to ask if there have been any new developments.

Thank you,

Garry Pshonik

On Mon, Feb 5, 2024 at 2:49 PM Kara Tragesser <Kara.Tragesser@wdm.iowa.gov> wrote:

Hi,

They haven't submitted a plan to install the court as of now. Thanks for checking in.

Kara -

From: Garry Pshonik <gpshonik@gmail.com>
Sent: Monday, February 5, 2024 2:47 PM
To: Kara Tragesser <Kara.Tragesser@wdm.iowa.gov>
Subject: Re: [EXT] Proposed Arcadia Building Pickleball Courts

Hi Kara,

Just wanted to send a quick note to ask if you have any new information on this project.

Thank you!

Garry Pshonik

On Thu, Dec 28, 2023 at 11:08 AM Kara Tragesser <Kara.Tragesser@wdm.iowa.gov> wrote:

Garry,

Thank you for calling and expressing your concerns. If R&R does submit a plan in the future, I will be more alert to the location of any significant noise improvement they propose next to the residential.

Regards,

Kara

Kara V. Tragesser, AICP
Development Services
City of West Des Moines
PO Box 65320
4200 Mills Civic Parkway Suite 1D
West Des Moines IA 50265-0320
P: 515-222-3620

From: Garry Pshonik <gpshonik@gmail.com>
Sent: Wednesday, December 27, 2023 4:37 PM
To: Kara Tragesser <Kara.Tragesser@wdm.iowa.gov>
Subject: [EXT] Proposed Arcadia Building Pickleball Courts

Hi Kara,

Thank you so much for your time today regarding the proposed pickleball courts for the Arcadia office building makeover. I truly appreciate your willingness to discuss these matters with R&R Realty, and also want to express my sincere gratitude for your empathy and professionalism listening to my concerns.

As we discussed, from both a homeowner's and professional office worker's perspective, I firmly believe pickleball courts are a poor fit for residential areas and corporate office settings due to the extremely loud and highly repetitive noise associated with the sport, which causes significant disturbance and distress to individuals in their homes and workplaces. Should R&R decide to proceed with installing these courts, your suggestion to ask them to relocate farther west near Office Plaza Drive and implement additional noise mitigation measures seems a better fit to the area. The birds and other wildlife who enjoy the peaceful setting of the two ponds would no doubt agree!

For reference, I am including a map of the area that appeared in the Des Moines Register article with the proposed pickleball court location and have highlighted the areas of concern regarding noise nuisance.



I will follow up with you in about a month as you suggested.

Thank you again for your help!

Garry Pshonik

1248 66th St.

515-577-8645

Members of West Des Moines Planning and Zoning Commission and City Council,

I am writing to express my concerns about the proposed installation of two outdoor pickleball courts by R&R Realty near residential homes as part of the Arcadia Building renovation. While community development is welcome, the potential noise impact of pickleball courts poses a significant threat to the peace and quality of life for neighboring residents.

Pickleball can generate extremely high noise levels, reaching up to 85 dBA (as loud as freeway traffic sound) and is significantly louder than normal outdoor background noise of around 55 dBA. The high pitch of the paddle hitting the ball and the unpredictable, rapid tempo of the game contribute to the disturbance. These elements combine to create a repetitive, impulsive sound that can be particularly irritating as the human ear is especially sensitive to the frequencies produced by the pickleball "pop," making the perceived loudness even worse. "Pickleball sound exists right in that most sensitive range. An interesting thing (...) is that garbage truck backup beepers are right in the same pitch of pickleball. Why did they pick that sound for beepers? Because it's the most annoying frequency." (*Bob Unetich, pickleball player and certified pickleball referee, owner Pickleball Sound Mitigation, LLC, Interview, Iowa Public Radio/NPR, Fixing pickleball's noise problem, 2023*). Research also shows that excessive noise from pickleball courts can have a detrimental effect on nearby property values, potentially reducing them by 10-20% (Financial Samurai, 2023). This presents an undue financial burden on residents through no fault of their own.

To further substantiate these concerns, I would like to submit the following references for your consideration:

1. The "**Pickleball Noise Impact Assessment and Abatement Planning**" [**Lance Willis, PhD, Spendiarian & Willis Acoustics & Noise Control LLC, 2023**] study conducted in 2023 by an acoustical engineering firm for the City of Centennial, Colorado, which describes the noise issues of pickleball courts near residential areas and the limitations of typical noise mitigation strategies (Centennial, 2023).

Executive Summary

As pickleball grows in popularity across North America it has become necessary to define more accurate methods of assessing the noise impact of the sport on the surrounding community and plan effective strategies for integrating it into various recreational venues. The purpose of this document is to provide descriptions of measurement protocols appropriate for assessing short duration impulsive sound such as pickleball and paddle impacts, definitions of terms and acoustical metrics, and guidance for acoustical planning of new pickleball courts. Basic methodologies and best practices for community noise assessment, environmental acoustics measurements, and noise regulation documents are described.

The main concern for neighbors living close to pickleball courts is the popping sound produced by the paddle when it strikes the ball. This sound is narrowband, imparting a sensation of pitch, and very short in duration. For the latter reason, measurement techniques that involve averaging the sound pressure over time tend to underestimate the noise impact of the impulsive sound produced by the paddles. For this type of sound, the noise assessment methodology described in ANSI S12.9 Part 4 for the highly impulsive classification of sound, based on adjusted sound exposure level, is recommended as the most accurate means of assessing the community response to pickleball paddle impacts.

Planning open air pickleball courts begins with selecting an appropriate site that has sufficient setbacks to ensure an effective noise abatement plan will be possible. Most of the work of reducing sound levels at the neighbors is done by noise barriers in the form of sound walls or mass-loaded vinyl (MLV) fence covers. These are, however, limited in the amount of noise reduction they can provide making setbacks a critical component for success of the overall noise abatement plan. In order for a noise barrier to provide acoustical shielding it must be able to block the line of sight from the players on the pickleball courts to the surrounding noise sensitive areas including upper level windows and raised decks. These geometrical considerations, which will include topography as well as the neighboring structures themselves, may affect the minimum setbacks needed in a particular application.

10.1 When a Noise Impact Assessment Is Needed

Courts located within 350 feet of residential properties in most cases require noise abatement. Pickleball court sites within 500 to 600 feet of noise sensitive areas should be reviewed by a qualified acoustical engineer in the site selection phase of the project. In the case that the ground between the pickleball courts and receiving property is water this distance may extend 800 to 1,000 feet in some cases. Courts located within 150 feet of homes require careful and often extensive noise abatement design to avoid complaints. Placing open air pickleball courts within 100 feet of residential properties is not recommended.

10.2 Site Selection

10.2.1 Available Setbacks

The most important factor to consider in selecting a site for pickleball courts is the distance to adjacent residential land uses. While a noise barrier such as a sound wall or mass-loaded vinyl fence cover can be effective in reducing noise impact, it can only provide a limited amount of insertion loss, usually between 8 and 12 dB depending on the ground it is installed on, flanking paths, reflecting surfaces, and other factors. The rest of the noise reduction required to meet acceptable sound levels must mostly be gained through distance. It is important to ensure that there is enough buffer so that noise abatement installed can be adequately effective. Other site conditions that may increase the setback required are discussed in the following subsections.

10.2.2 Proximity to Multi-story Residential Structures

In order for a noise barrier to be effective it must be able to block the line of sight from the sound source to the receiving land use. Pickleball paddle impacts can occur from near the elevation of the playing surface to a height of about 8 feet above it. Multi-story housing located close to the proposed pickleball courts may not be adequately shielded a wall system. This can affect upper level windows, balconies, raised decks, other amenities located above ground level. These need to be included in the noise impact assessment of the proposed pickleball courts.

9.4.2 Roadways

Roadways are a broadband, continuous sound source. In general, even busy highways are not able to mask pickleball courts due to the high peak sound pressures of the paddle impacts. Traffic noise tends to be mostly low to mid frequency sound and does not have sufficient energy in the 1,000 Hz octave band to effectively mask pickleball.

It appears to be a common perception that placing pickleball courts in neighborhoods located close to main arteries or interstates will prevent noise issues due to the sound from the roadway. In practice, this has not proven to be the case as seen at Glenhaven Park in La Cañada Flintridge, California [La Cañada Flintridge]. This neighborhood park is located adjacent to Interstate 210 on the north side of Los Angeles.

2. Articles from mainstream sources such as The New York Times, which have reported on the widespread "pickleball noise complaints" and how people have compared the sound to "a pistol range, torture, and even hell" (The New York Times, 2023).
3. A report from KPBS news on "Homeowners increasingly taking legal action over pickleball noise" as the issue becomes more prevalent across the country (KPBS, 2023). <https://www.kpbs.org/news/quality-of-life/2023/09/05/homeowners-are-increasingly-taking-legal-action-over-pickleball-noise>
4. City of Lake Oswego, OR City Council Meeting Testimony from Dr. Jenny Davies public and environmental health director for a National Environmental Education nonprofit, who provided expert evidence on the public health impacts of chronic, persistent, and repetitive environmental noise like that from pickleball courts (Davies, 2023). https://www.youtube.com/watch?v=gPP915_ilms

As stated in the Centennial study's executive summary, the main concern is the "popping sound produced by the paddle when it strikes the ball" which is "narrowband, imparting a sensation of pitch, and very short in duration." This type of impulsive sound is particularly disruptive and cannot be adequately addressed through standard noise reduction methods. Adequate setbacks from residences are critical, but even then, barriers and other mitigation may be insufficient.

Likewise, section 10, **Site Planning Considerations for Pickleball** discusses the importance of site selection and planning for pickleball courts. The study states that courts located within 350 feet of residential properties typically require noise abatement measures. Courts within 500 to 600 feet of noise sensitive areas, or up to 800 to 1,000 feet if there is water between the courts and receivers, should be reviewed by a qualified acoustical engineer to assess the potential impacts. The majority of the neighboring residential areas fall within the distances stated above.

I urge the members to thoroughly consider these issues and their implications while evaluating the proposal.

Sincerely,

Garry Pshonik
1248 66TH ST, WDM

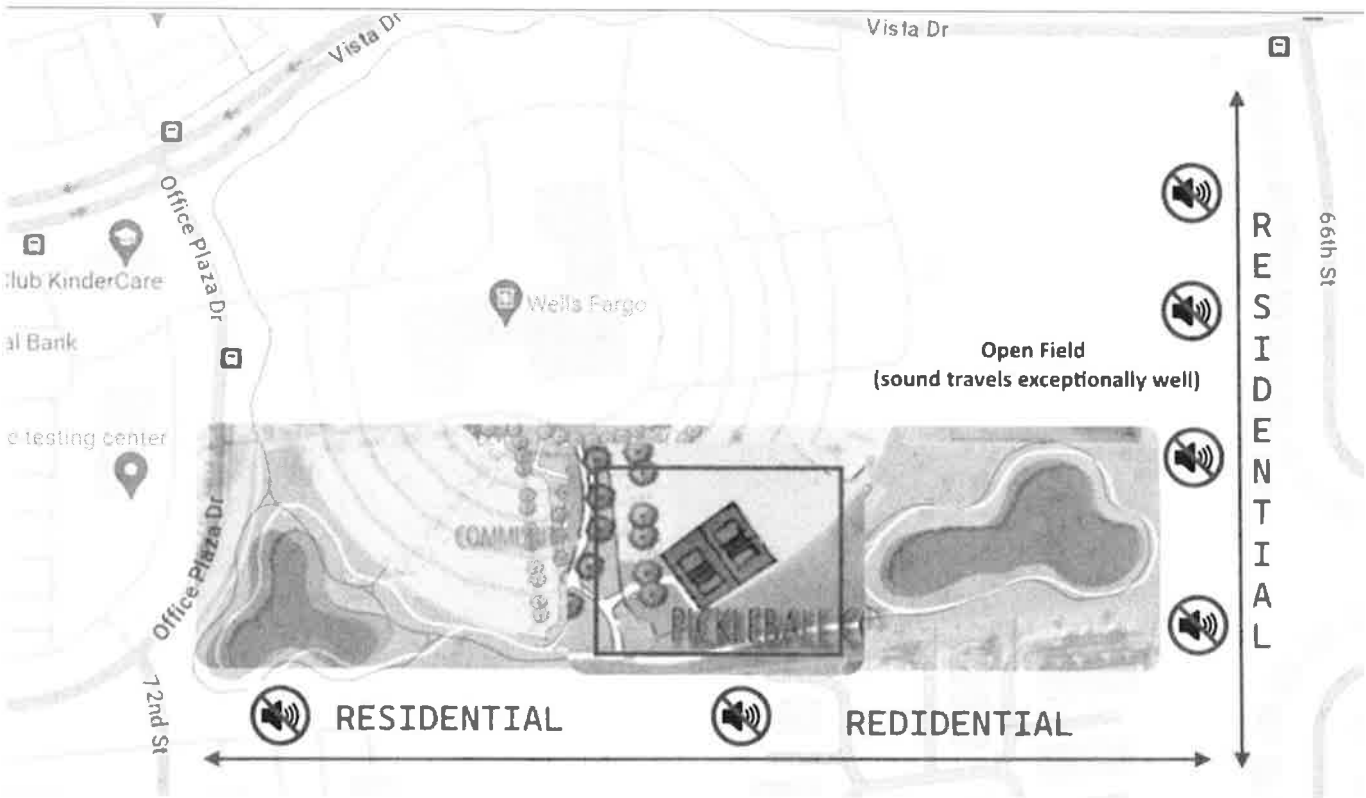

References:

- Pickleball Noise Impact Assessment and Abatement Planning (2023). Centennial, CO: City of Centennial, Spendiarian & Willis Acoustics & Noise Control LLC <https://www.centennialco.gov/files/sharedassets/public/documents/city-projects-and-initiatives/centennial-pickleball-noise-assessment.pdf>
- Financial Samurai. (2023). Quantifying Pickleball's Impact on Real Estate Prices: Mostly Negative. <https://www.financialsamurai.com/quantifying-pickleball-impact-on-real-estate-prices/>
- NPR/Iowa Public Radio: Fixing pickleball's noise problem (2023) <https://www.iowapublicradio.org/2023-06-08/fixing-pickleballs-noise-problem>
- KPBS. (2023). Homeowners are increasingly taking legal action over pickleball noise. <https://www.kpbs.org/news/quality-of-life/2023/09/05/homeowners-are-increasingly-taking-legal-action-over-pickleball-noise>
- The New York Times. (2023). Pickleball noise complaints driving us all crazy. <https://www.nytimes.com/2023/06/30/sports/pickleball-noise-complaints-lawsuits.html>
- Cutler, Amy, "Rise of pickleball pitting neighbor against neighbor, leading to lawsuits," (2023) Arizona's Family, Phoenix, Arizona. <https://www.azfamily.com/2023/02/13/rise-pickleball-pitting-neighbor-against-neighbor-leading-lawsuits/>
- Arden, Amanda, "Lake Oswego shuts down city pickleball courts indefinitely due to noise complaints." (2023) KION 6 News, Portland, Oregon. <https://www.koin.com/local/lake-oswego-shuts-down-city-pickleball-courts-indefinitely-due-to-noise-complaints/>
- Columbo, Mike, "Pickleball plan pits Kirkwood residents against neighboring country club." (2023) Fox 2 Now, Saint Louis, Missouri. <https://fox2now.com/news/contact-2/pickleball-plan-pits-kirkwood-residents-against-neighboring-country-club/>
- Sheets, Connor, "Pickleball noise is fueling neighborhood drama from coast to coast." (2022) Los Angeles Times, Los Angeles, California. <https://www.latimes.com/california/story/2022-03-03/pickleball-noise-fueling-neighborhood-drama>
- Adler, Erin, "Apple Valley neighbors in a pickle over pickleball noise." (2019) Star Tribune, Minneapolis, Minnesota. <http://www.startribune.com/apple-valley-neighbors-in-a-pickle-over-pickleball-noise/507726242/>
- Bartel, Mario, "Pickleball banished from Port Moody court after neighbours complain of rising stress, anxiety." (2021) The Tri-City News, Coquitlam, British Columbia, Canada. <https://www.tricitynews.com/local-sports/these-games-are-loud-port-moody-pickleball-neighbours-revolt-against-rising-stress-anxiety-3662369>
- City of Lakewood, "Green Mountain Courts Closure." https://www.lakewoodtogether.org/pickleball/news_feed/green-mountain-courts-update
- Higgins, Sean, "No vote on residential pickleball until city adopts new land management code." (2022) KPCW News, Park City, Utah. <https://www.kpcw.org/park-city/2022-01-27/no-vote-on-residential-pickleball-until-city-adopts-new-land-management-code>
- Maryniak, Paul, "Pickleball lights plan puts two HOAs at loggerheads." (2017) Ahwatukee Foothills News, Tempe, Arizona. https://www.ahwatukee.com/news/article_9056a946-d48e-11e7-9838-8b69fb2d50b2.html
- Bottemiller, Kitty, "Too loud! Pickleball noise upsets neighbors." (2013) Green Valley News, Green Valley, Arizona. https://www.gvnews.com/news/local/too-loud-pickleball-noise-upsets-neighbors/article_542c2aac-0f91-11e3-acdc-0019bb2963f4.html
- Clay, Joanna, "Woman sues Newport Beach over pickleball noise at park near her home." (2016) Orange County Register, California. <https://www.ocregister.com/2016/04/07/woman-sues-newport-beach-over-pickleball-noise-at-park-near-her-home/>
- Wheatley, Mike, "Noisy pickleball courts cause upset with homeowners." (2022) Realty Biz News. <https://realtybiznews.com/noisy-pickleball-courts-cause-upset-with-homeowners/98768719/#:~:text=In%20one%20lawsuit%20in%20Newport%20Beach%2C%20Calif.%2C%20a,are%20causing%20them%20less%20enjoyment%20of%20their%20home>
- Lazaruk, Susan, "Pickleballers face off with residents over noise in Metro Vancouver." (2022) Vancouver Sun, Toronto, Ontario, Canada. <https://vancouversun.com/news/local-news/pickleballers-face-off-with-residents-over-noise-in-metro-vancouver>
- Shanes, Alexis, "Village in a pickle: How Ridgewood plans to tone down the pickleball court noise." (2020) northjersey.com, California. <https://www.northjersey.com/story/news/bergen/ridgewood/2020/01/16/ridgewood-nj-pickleball-noise-reduction-measures/4480463002/>
- Monterey Herald Staff, "Pickleball noise controversy goes before city leaders Pacific Grove neighbors object to game at nearby tennis courts." (2019) The Mercury News, California <https://www.mercurynews.com/2019/09/19/pickleball-noise-controversy-goes-before-city-leaders/>
- Fraser, Patrick and Rodriguez, Ambar, "What to do about constant pickleball noise?" (2019) WSVN 7 News Miami, Miami, Florida. <https://wsvn.com/news/help-me-howard/what-to-do-about-constant-pickleball-noise/>



Spendiarian & Willis Acoustics & Noise Control LLC

The Form and Function of Sound

(520) 623-6003

AcousticalNoise.com

4335 N Alvernon Way, Tucson, AZ 85718

Pickleball Noise Impact Assessment and Abatement Planning

Prepared for

**City of Centennial
13133 E. Arapahoe Road
Centennial, Colorado 80112**

**Project Manager
Neil Marciniak**

Lance Willis, PhD

© Spendiarian & Willis Acoustics & Noise Control LLC

R. 0, July 11, 2023

Spendiarian & Willis Acoustics & Noise Control LLC

1 of 77

Executive Summary

As pickleball grows in popularity across North America it has become necessary to define more accurate methods of assessing the noise impact of the sport on the surrounding community and plan effective strategies for integrating it into various recreational venues. The purpose of this document is to provide descriptions of measurement protocols appropriate for assessing short duration impulsive sound such as pickleball and paddle impacts, definitions of terms and acoustical metrics, and guidance for acoustical planning of new pickleball courts. Basic methodologies and best practices for community noise assessment, environmental acoustics measurements, and noise regulation documents are described.

The main concern for neighbors living close to pickleball courts is the popping sound produced by the paddle when it strikes the ball. This sound is narrowband, imparting a sensation of pitch, and very short in duration. For the latter reason, measurement techniques that involve averaging the sound pressure over time tend to underestimate the noise impact of the impulsive sound produced by the paddles. For this type of sound, the noise assessment methodology described in ANSI S12.9 Part 4 for the highly impulsive classification of sound, based on adjusted sound exposure level, is recommended as the most accurate means of assessing the community response to pickleball paddle impacts.

Planning open air pickleball courts begins with selecting an appropriate site that has sufficient setbacks to ensure an effective noise abatement plan will be possible. Most of the work of reducing sound levels at the neighbors is done by noise barriers in the form of sound walls or mass-loaded vinyl (MLV) fence covers. These are, however, limited in the amount of noise reduction they can provide making setbacks a critical component for success of the overall noise abatement plan. In order for a noise barrier to provide acoustical shielding it must be able to block the line of sight from the players on the pickleball courts to the surrounding noise sensitive areas including upper level windows and raised decks. These geometrical considerations, which will include topography as well as the neighboring structures themselves, may affect the minimum setbacks needed in a particular application.

Table of Contents

1. Introduction	7
1.1 Pickleball and Pickleball Sound	7
1.2 Properties of Sound	8
1.3 Annoyance	8
1.4 Physiological Effects of Sound	9
1.5 Long Term and Short Term Community Impact	10
2. Definitions	12
3. Noise Regulation Best Practices	15
3.1 Purpose	15
3.2 Measurement Procedures	16
3.3 Common Ordinance Noise Descriptors	16
3.4 Reducing Vagueness	17
3.5 Current Standards in Noise Regulation	17
3.5.1 European Union Directive 2002/49	17
4. Classification of Environmental Sound	18
4.1 Amplitude Characteristics	18
4.1.1 Sound Pressure	18
4.1.2 Broadband Continuous Sound	19
4.2 Spectral Characteristics	20
4.2.1 Broadband	20
4.2.2 Narrowband	20
4.2.3 Tonal	20
4.2.4 Infrasound and Ultrasound	20
4.3 Temporal Characteristics	20
4.3.1 Stationary or Continuous	20
4.3.2 Impulsive	21
Highly Impulsive	21
High Energy Impulsive	21
Regular Impulsive	21
Modulated	22
4.3.3 Time of Occurrence	22
4.4 Ensemble and Background Sound Pressure Levels	22
5. Measurement and Assessment of Environmental Sound	23
5.1 Quantification of Sound	23
5.1.1 Sound Pressure	23
5.1.2 Frequency Weighting	23
5.1.3 Equivalent-continuous Sound Pressure Level	25
5.1.4 Day Night Level	25
5.1.5 Percentiles	26
5.1.6 Sound Exposure Level	26
5.1.7 Peak Sound Pressure Level	26

5.2	Acoustical Instrumentation	26
5.2.1	The Sound Level Meter	26
5.2.2	Exponential Time Weighting	27
5.2.3	Integrating Sound Level Meters	27
5.2.4	Frequency Band Analysis	27
5.2.5	Calibration	27
5.3	Calculation Methods	28
5.3.1	Decibel Addition	28
5.3.2	Background Noise Correction	29
5.4	Measurement Procedures	30
5.4.1	Field Calibration	30
5.4.2	Measurement Conditions	31
5.4.3	Measurement Locations	31
5.4.4	Sound Level Meter Placement	31
5.4.5	One Hour Equivalent-continuous Sound Pressure Level Measurements	31
5.5	Adjusted Sound Pressure Levels	32
5.5.1	Assessing Tonal Sounds	32
5.5.2	Assessing Impulsive Sounds	32
5.5.3	Applying Adjustments Using Sound Exposure Level	32
5.5.4	Time of Day Adjustments	34
5.6	Measurement Reports	34
5.7	Noise Impact Assessments	35
5.7.1	Purpose and Methods	35
5.7.2	Present and Future Noise Exposure	35
5.8	Existing Noise Regulations	35
5.8.1	City of Centennial Municipal Code, Chapter 10, Article 12	35
5.8.2	Colorado Revised Statutes 25-12-101	36
6.	Characteristics of Pickleball Sound	38
6.1	Comparison of Pickleball to Other Activities	38
6.2	Effects of Impulsive Sound	40
6.3	Acoustical Characteristics	40
6.4	Directivity of Pickleball Courts	43
6.5	Noise Impact of Speech	44
7.	Influence of Environmental Factors	46
7.1	Number and Arrangement of Pickleball Courts	46
7.2	Topography	50
7.2.1	Sight Lines	50
7.2.2	Noise Sensitive Locations Above Ground Level	50
7.3	Ground	52
7.3.1	Attenuation	52
7.3.2	Refraction	53
7.3.3	Valleys	53
7.3.4	Water	53
7.4	Reflective Surfaces	53
8.	Noise Assessment Procedures for Pickleball Sound	55

8.1	Inaccuracies of Simple Averaging Techniques	55
8.1.1	Equivalent-continuous Sound Pressure Level	55
8.1.2	Exponential Time Weighting	55
8.1.3	Percentile Sound Pressure Levels	57
8.2	Best Practices for Assessment of Impulsive Sound	58
8.3	Measurement Procedures for Highly Impulsive Sound	59
8.3.1	Measuring the Paddle Impacts	59
8.3.2	Measuring Background Levels	59
8.3.3	Data Analysis	60
	Sound Exposure Level	60
	Background Noise Correction	60
	Adjusted Sound Pressure Level	60
8.4	Noise Assessment of Spectator Speech	60
8.5	Site Simulation	61
8.5.1	Modeling Distributed Sound Sources	61
8.5.2	Pickleball Court Directivity	63
9.	Noise Abatement Methods	65
9.1	Setbacks	65
9.2	Noise Barriers	65
9.2.1	Performance Requirements	65
9.2.2	Fence Cover Safety Notice	66
9.2.3	Parallel Surfaces	66
9.2.4	Lowering Pickleball Courts	67
9.2.5	Ventilation and Air Flow	68
9.3	Court Orientation	68
9.4	Sound Masking	68
9.4.1	Masking Requirements	68
9.4.2	Roadways	69
9.4.3	Fountains	69
9.5	Full Enclosure of Pickleball Courts	69
9.6	Noise Control Policy	70
9.6.1	Hours of Operation	70
9.6.2	Restrict Players Allowed to Use Courts	70
9.6.3	Speech	70
9.6.4	Restrictions on Equipment	70
	Quieter Equipment	70
	Paddles	70
	Foam Balls	71
10.	Site Planning Considerations for Pickleball	72
10.1	When a Noise Impact Assessment Is Needed	72
10.2	Site Selection	72
10.2.1	Available Setbacks	72
10.2.2	Proximity to Multi-story Residential Structures	72
10.2.3	Topography	72
10.3	Tournaments	73

11. Conclusions	74
11.1 Best Practices in Noise Assessment and Regulation	74
11.2 Characteristics of Pickleball Sound	74
11.3 Noise Impact Assessment of Pickleball	74
11.4 Noise Abatement Planning	74
11.5 Site Planning	75
References	76

Table of Figures

Figure 1.1. Pickleball Game.....	7
Figure 4.1. Sound Pressure Levels of Some Common Sources.....	19
Figure 5.1. ISO 226 Equal Loudness Contours.....	24
Figure 5.2. ANSI S1.4-2014 Frequency Weighting Curves.....	25
Figure 5.3. Decibel Addition.....	28
Figure 5.4. Background Noise Correction.....	30
Figure 6.1. Pickleball Paddle and Ball Impact Sound Pressure Trace.....	41
Figure 6.2. Spectral Response of a Sharp Hit.....	42
Figure 6.3. Spectral Response of a Dull Hit.....	43
Figure 6.4. Typical Pickleball Court Directivity in Decibels.....	44
Figure 7.1. Adjusted Sound Pressure Level from Four Pickleball Courts.....	47
Figure 7.2. Adjusted Sound Pressure Level from Eight Pickleball Courts Aligned Longitudinally	48
Figure 7.3. Adjusted Sound Pressure Level from Eight Pickleball Courts Aligned Laterally.....	49
Figure 7.4. Adjusted Sound Pressure Level Contours, Four Courts, 10 Foot Wall, 5 Foot Elevation.....	51
Figure 7.5. Adjusted Sound Pressure Level Contours, Four Courts, 10 Foot Wall, 15 Foot Elevation.....	52
Figure 8.1. Fast Time Averaging Filter Response to a 0.277 Second Sound Burst.....	56
Figure 8.2. Fast Time Averaging Filter Response to a Typical Pickleball Paddle Impact.....	57
Figure 8.3. Pickleball Court Dimensions.....	62
Figure 8.4. Sound Pressure Level at Distance from Court Center for One and Two Sources.....	63
Figure 9.1. Performance Comparison of Interior Parallel Surfaces of Noise Barriers.....	67
Figure 9.2. Sound Wall Overlap.....	68

Index of Tables

Table 1.1. Application of Short and Long Term Noise Regulation.....	11
Table 8.1. Pickleball Court Directivity Pattern.....	64

1. Introduction

1.1 Pickleball and Pickleball Sound

Pickleball is popular and rapidly growing paddle sport in the United States and Canada. It is played with a hard plastic ball similar to a wiffle ball. A pickleball court is 44 feet long and 20 feet wide compared to a tennis court at 78 feet long and 36 feet wide. A tennis court can be converted into four pickleball courts.



Figure 1.1. Pickleball Game

As the sport has grown so have concerns from those living near pickleball courts over noise. The impact of the pickleball on the paddle causes a sharp popping sound that can be heard hundreds

of feet from the courts. Unfortunately, poor siting and inadequate noise impact assessment and abatement at many locations have made open air pickleball courts controversial additions in many neighborhood settings. This document will provide guidance on noise impact assessment in general, how to accurately measure the sound produced by pickleball courts, site selection, and effective mitigation treatments.

1.2 Properties of Sound

Sound, for the purposes of this document, is a small pressure disturbance in the atmosphere producing the sensation of hearing. It may be produced by the vibration of a surface or by the pulsation of an airstream such as a rotating fan blade or the human vocal cords. Sound propagates through the atmosphere as a compression wave with a speed that increases with the temperature of the air. The characteristics of a particular sound are described in terms of amplitude (loudness), frequency (pitch), and the change of amplitude and frequency with time (impulsiveness, modulation, onset rate, or rise time).

Noise is unwanted sound. This may be a subjective assessment or it may imply effects on health, well being, and speech communication. Community noise impact is assessed in terms of both annoyance and public safety.

1.3 Annoyance

The subjective aspect of noise is known as “annoyance.” Annoyance describes the quality of a sound that is perceived as objectionable. It differs from loudness, the perceived amplitude of a sound. Annoyance is often influenced by nonacoustic factors such as habituation or sensitization to the sound, involvement in activities that require concentration, attitudes towards sound sources and their operators, and the perceived necessity of the noise intrusions. For these reasons, reports of annoyance will have varying degrees of response bias.

Annoyance as a basis for determining acceptable noise levels can be traced to a paper by T. J. Schultz [Schultz, 1978] and the work of other researchers in the 1960's and 1970's. Schultz aggregated a group of social surveys regarding transportation noise in different cities and found that the results could be explained using a noise dosage relationship. This method has since been adopted by federal agencies tasked with regulating and evaluating road, rail, and air transportation noise.

Early research into the community impact of noise focused mainly on road traffic noise. As a result, other sound sources studied later were compared to traffic noise impact studies to determine their level noise impact. It was found that the sound pressure levels of sound sources having special characteristics such as impulsiveness and tonality did not correlate well with community questionnaires when directly compared to traffic sound pressure levels. The annoyance of these sources was often higher than the traffic noise for the same sound pressure level.

For this reason, the sound pressure levels of sound sources having these special characteristics are given an adjustment to compensate for the difference in noise impact. Part 4 of the ANSI S12.9 standard gives adjustments and measurement methodologies for a variety of sound

classifications and is used as the basis for the sound pressure level adjustments in this document.

1.4 Physiological Effects of Sound

While it is well known that high amplitude acoustical pressures can cause hearing impairment as well as other types injury to the body, lower amplitude sound can also have adverse long term physiological effects.

The World Health Organization recognizes that low level noise exposure has measurable health effects:

Sound/noise is a psychosocial stressor that activates the sympathetic and endocrine system. Acute noise effects do not only occur at high sound levels in occupational settings, but also at relatively low environmental sound levels when, more importantly, intended activities such as concentration, relaxation or sleep are disturbed. [WHO, *Night Noise Guidelines*, p. 61]

The sympathetic nervous system is part of the autonomic nervous system and is involved in the body's fight or flight arousal response. Chronic activation of the sympathetic system leads to stress, fatigue, and anxiety.

In addition to nervous system activation, sleep disturbance from noise can involve difficulty in falling asleep as well as awakenings that occur during sleep. Frequent awakenings lead to sleep fragmentation. This disrupts the normal stages of sleep and may lead to further neurocognitive manifestations not limited to daytime tiredness, loss of concentration, morning confusion, irritability, anxiety, and depression. [WHO, *Night Noise Guidelines*, p. 48, 26]

Environmental noise also has implications for the cardiovascular system, metabolism, and homeostasis, the ability of the body to regulate itself.

The auditory system is continuously analyzing acoustic information, which is filtered and interpreted by different cortical and subcortical brain structures. The limbic system, including the hippocampus and the amygdala, plays an important role in the emotional processing pathways. It has a close connection to the hypothalamus that controls the autonomic nervous system and the hormonal balance of the body. Laboratory studies found changes in blood flow, [blood pressure] and heart rate in reaction to noise stimuli as well as increases in the release of stress hormones... Acoustic stimulation may act as an unspecific stressor that arouses the autonomic nervous system and the endocrine system... The arousal of the sympathetic and endocrine system is associated with changes in the physiological functions and the metabolism of the organism, including [blood pressure], cardiac output, blood lipids (cholesterol, triglycerides, free fatty acids, phosphatides), carbohydrates (glucose), electrolytes (magnesium, calcium), blood clotting factors (thrombocyte, aggregation, blood viscosity, leukocyte count) and others. In the long term, functional changes and dysregulation may occur, thus increasing the risk of manifest diseases. [WHO, *Night Noise Guidelines*, p. 62-63]

The effects of stress can take many forms as seen above. Low level noise exposure that disturbs

sleep and concentration are known to produce a range of diagnosable illnesses and disorders.

1.5 Long Term and Short Term Community Impact

Community response to noise is different for short term and long term exposures. Short term impact refers to sounds that occur occasionally for a limited period of time, usually on an irregular basis, that are not part of the normal activities on a property. These types of sounds are generally addressed in the municipal code.

Zoning or land use regulations focus on long term community noise impact. These sounds occur regularly over a period of time measured in weeks, months, or years and are usually part of the normal activities on a property. In most cases, however, this would not include construction activities as these are temporary and not a normal part of the usage of the site.

Municipal code noise regulations and land use code noise regulations serve different purposes, but compliment each other to protect the community from excessive noise under differing circumstances. The land use code governs long term community noise exposure and is directed mainly to developers and commercial property owners. A municipal code applies to short term noise sources that generally do not operate on a regular basis. The table below shows a comparison of how these two codes work separately and together to provide a more complete community noise policy.

Table 1.1. Application of Short and Long Term Noise Regulation

	Municipal Code	Land Use Code
Assessment Type:	Short term noise impact	Long term noise impact
Directed Toward:	Residents, public gatherings, noise control officers, police officers	Developers, architects, acoustical engineers, planning & development dept., noise control officers
Purpose:	<ul style="list-style-type: none"> • Set threshold for offenses • Define penalties 	<ul style="list-style-type: none"> • Guidance for site planning • Standards for noise abatement • Long term noise assessment
Main Area of Law:	Criminal	Civil
Findings:	<ul style="list-style-type: none"> • Made by officer on scene • Immediate determination of required action 	<ul style="list-style-type: none"> • Assessment of all sound sources affecting surrounding properties by acoustical engineer • Analysis presented in detailed report
Expected Outcomes:	<ul style="list-style-type: none"> • Immediate action • Possible cease and desist order, citation, or arrest 	<ul style="list-style-type: none"> • Comprehensive plan to bring the site into compliance • Installation of noise abatement treatments

2. Definitions

A-weighted sound level

A measurement of a sound level obtained using “A” frequency weighting. This weighting curve approximates the frequency response of human hearing for low to moderate sound pressure levels. The frequency weighting characteristics of the A-weighting filter are defined in ANSI S1.42 and ANSI S1.4.

Background sound

Sound from all existing sources near and far that may interfere with a sound pressure level measurement, not to include the sound source being evaluated.

Decibel (dB)

Ten times the logarithm to the base ten of the ratio of two quantities that are proportional to power. Quantities denoted as a “level” are decibel quantities, e.g. sound pressure level.

Ensemble sound

Sound from all normal existing sources near and far at a given location, including the sound source being evaluated. The union of all sound sources observable at the point of assessment.

Equivalent-continuous sound pressure level

The sound pressure level of a steady, continuous sound having the same sound energy as the time varying sound measured. Ten times the logarithm to the base ten of the time average over the period of a measurement of the square of the ratio of the sound pressure to the reference sound pressure of 20 micropascals expressed in decibels (dB).

Fast exponential time weighting

A lowpass filter for the purpose of averaging or smoothing a signal having a time constant of 0.125 seconds applied to the square of the sound pressure as specified in ANSI S1.4-1983.

Highly impulsive sound

Impulsive sound having very rapid onset rate or rise time typically resulting from impact processes or small arms gunfire including, but not limited to: metal hammering, wood hammering, drop hammering, pile driving, drop forging, pneumatic hammering, pickleball paddle and ball impacts, pavement breaking, metal impacts during rail-yard shunting operation, and riveting. ISO 1996 differentiates highly impulsive sound from regular impulsive sound by its noted level of intrusiveness.

Impulsive sound

Sound that is characterized by brief excursions of sound pressure, typically less than one second, whose peak pressure noticeably exceeds the background sound pressure.

Insertion loss (IL)

For a sound attenuator, noise barrier, or other noise abatement treatment, the decrease in sound level at a point of observation when the noise abatement treatment is inserted between the sound source and point of observation.

Noise

Any sound which annoys or disturbs humans or which causes or tends to cause an adverse effect on humans, domesticated animals, or livestock.

Noise abatement plan

A detailed plan demonstrating the mitigation measures to be taken in order to meet the requirements of this noise regulation. The noise abatement plan should describe the construction and locations of abatement treatments with the expected sound pressure levels at the receiving properties.

Noise impact assessment

An analysis performed by a qualified acoustical engineer which determines the potential noise impacts of a proposed use.

Peak sound pressure

The largest absolute value of the instantaneous sound pressure in pascals (Pa) in a stated frequency band during a specified time interval.

Regular impulsive sound

Impulsive sound that is not highly impulsive sound. This includes speech and music.

Sound exposure level (SEL)

Sound exposure level is a descriptor for characterizing the sound from individual acoustical events. The sound exposure is the time integral of the square of the sound pressure over a time interval equal to or greater than an acoustical event having units of pascal squared seconds. The sound exposure level is ten times the logarithm to the base ten of the ratio of the sound exposure to the product of the square of the reference sound pressure of 20 micropascals and the reference time of one second expressed in decibels (dB).

Sound level meter (SLM)

An instrument used to measure sound pressure levels meeting the Type 1 standards for accuracy in ANSI S1.4-1983. Integrating sound level meters shall comply with ANSI S1.43-1997 Type 1. If octave band or fractional octave band filters are used, they shall comply with ANSI S1.11-2004 Class 1.

Sound pressure

A disturbance or perturbation of the atmospheric pressure with respect to the mean barometric pressure producing the sensation of hearing or vibration measured in units of pascal (Pa).

Sound pressure level (SPL)

20 times the logarithm to the base 10 of the ratio of the sound pressure to the reference sound pressure of 20 micropascals (μPa) expressed in decibels (dB).

Tonal sound

Sound having one or more single frequency oscillations (pure tones) or that is confined to a narrow band of frequencies meeting the criteria for tonal prominence. See ANSI S12.9 Part 4 Annex C or ANSI S1.13 Annex A.

3. Noise Regulation Best Practices

3.1 Purpose

A community is made up of individuals, families, businesses, government, land owners, tenants, and other groups conducting activities for their livelihoods and enjoyment. The purpose of noise regulation is to find a balance between the legitimate activities of one group and the need for peace and quiet of another and to provide a clear process for resolving disputes when they arise. Zoning noise regulations provide design goals for developers in planning a site for a specific activity and serve as criteria for assessing the community noise impact of existing sites. Clear guidance with regard to acceptable sound pressure levels is essential for ensuring new projects conform to community standards and for evaluating the compliance of existing land uses.

Noise regulations should set clear and enforceable limits on community noise exposure that accurately reflect the community response to a variety of common sound sources. Overly strict regulations lead to arbitrary and selective enforcement while overly simplistic sound pressure level limits lead to the impact of certain classifications of sound being underestimated or ignored completely.

A well provisioned noise regulation will therefore provide a comprehensive and accurate methodology for assessing the most common classifications of sound that impact a community. This ensures that community noise impact will be evaluated in a way that is representative of the experience of living and working in the community and also protects property owners from unreasonable demands for mitigation. Most importantly the noise regulations should provide a definitive means for bringing noise disputes to resolution.

Key goals of noise regulation include:

- Provide quantitative design targets for noise abatement
- Provide protections for neighbors for all classifications of sound
- Protect property owners from drawn out noise disputes

Benefits of good noise regulation:

- Defined design requirements for developers
- Easier to get financing for projects due to lower risk and uncertainty
- Enforceable standards for compliance
- No cutting corners for contractor at risk

3.2 Measurement Procedures

Noise regulation generally takes the form of specifying maximum allowable A-weighted sound pressure levels at a given location. It is important that the locations specified for assessment and compliance be accessible such as at a property boundary.

Property boundary regulations protect the receiving property in its entirety against noise intrusions from adjacent sites. They also do not require entering private property in order to conduct acoustical testing. Performing acoustical measurements on the offending site creates bias due to the closer proximity to the sound source. Creating a noise abatement plan for new developments using noise assessment locations on the receiving property or inside a structure makes ensuring compliance more complicated. This will be discussed further in Section 3.3.

3.3 Common Ordinance Noise Descriptors

Noise ordinances often do not have objective limits on sound pressure level, but instead use subjective criteria to evaluate noise impact. This leads to a great deal of difficulty in resolving noise disputes since neither side can agree on what the terms mean.

One common term is “audible” or “plainly audible.” The problem with this criterion is that neighbors will always be audible at certain times depending on meteorological conditions, time of day, etc. This places everyone in violation of the noise code leading to arbitrary and selective enforcement. The threshold of audibility depends on the background noise level at a specific location and time. It is therefore unpredictable for site planning purposes and unrepeatable. There is also no practical way to monitor without setting up a surveillance style recording system and reviewing the playback to identify the source in question.

Another common ordinance criterion is “excessive, unnecessary or offensive noise which disturbs the peace or quiet of any neighborhood or which causes discomfort or annoyance to any reasonable person of normal sensitivity residing in the area.” This regulation puts the arbiter in the position of deciding who is a reasonable person and what constitutes normal sensitivity. It turns an engineering problem of assessing noise impact based on decades on scientific field studies into a personal problem with no clear guidance on consistent application or how to reach resolution.

The Maricopa County, Arizona Code, section P-23, prohibits sounds that can be “heard from within closed residential structures.” This code is unenforceable because it is untestable. First, it requires access to a private home or place of business. The home or business must then be searched to verify that all doors and windows are closed. For a developer it is impossible to plan for or ensure compliance with such an ordinance because it is dependent on the construction of the receiving structures.

The subjective criteria described above may be difficult to enforce due to vagueness. Under the vagueness doctrine a statute may be void if it leads to arbitrary enforcement, does not provide fair notice of what is and is not punishable, or does not detail the procedures followed by officers or judges of the law.

3.4 Reducing Vagueness

The first step in reducing vagueness in noise regulation is to adopt a comprehensive, objective standard that addresses the most common sources of noise complaints, particularly impulsive and tonal sounds. There should be separate criteria for short and long term noise impacts. The zoning or land use code should focus on long term impacts while the municipal code addresses short term nuisance noise. The standards should not be overly restrictive such that common, everyday activities cause violations leading to arbitrary enforcement.

Sounds that are subjectively negative and disturbing for contextual reasons may require enumeration and specific restrictions in addition to sound pressure level limits. This may involve use limitation to certain times of day, complete prohibition, or other policies as deemed appropriate to the situation. A 5 to 10 dB adjustment for the enumerated sound sources may also be an effective means to address their greater noise impact.

3.5 Current Standards in Noise Regulation

3.5.1 European Union Directive 2002/49

The current, most up to date noise regulations with regard to scientific research have been enacted through European Union Directive 2002/49. This directive implements the noise assessment methodology in International Organization for Standardization standard ISO 1996. The American adaptation of ISO 1996 is ANSI S12.9 Part 4. These standards provide a comprehensive, objective method to assess the community noise impact of the most common sources of noise complaints including broadband continuous, impulsive, and tonal sounds.

In addition to the assessment methodology, ANSI S12.9 Part 5 provides guidance for acceptable day-night levels for a variety of land uses. In practice, setting sound pressure level limits for residential, commercial, and industrial zoning areas is usually sufficient.

4. Classification of Environmental Sound

The impact of noise on a community is not always simply determined by the amplitude of the sound. Sounds that vary rapidly with time or have certain frequency characteristics can have an additional impact. This chapter discusses the classification of sounds with special characteristics and how they relate to community noise response.

4.1 Amplitude Characteristics

4.1.1 Sound Pressure

The most fundamental characteristic of sound is its pressure amplitude measured in units of Pascals (Pa). Due to the extremely wide sensitivity range of human hearing, sound pressure is normally presented on a logarithmic scale known as the decibel scale and denoted by the symbol, dB.

It is important to note that the decibel is a scale or unit of level, not a unit of measure. A decibel quantity must therefore have a reference value to define it. Any acoustic quantity described as a “level” is by definition on a decibel scale. The sound pressure level (SPL) is the sound pressure in Pascals normalized to the standard acoustical reference pressure of $20 \cdot 10^{-6}$ Pascals as follows,

$$SPL = 20 \log_{10} \left(\frac{p}{20 \cdot 10^{-6}} \right)$$

where p is the sound pressure in Pascals and SPL is the sound pressure level in dB.

Figure 4.1 shows some typical sound pressure levels of common sound sources. Sound pressure levels in the blue range are very quiet and usually found only in special environments such as anechoic test chambers or remote forest areas. The green range is typical of quiet environments. For outdoor sound, most daytime noise regulations begin to apply in the yellow range at starting 55 dBA. The U.S Department of Housing and Urban Development will require a noise abatement before funding residential projects above 65 dBA. Above 75 dBA they will require a stringent approval process. At 90 dBA in the workplace, OSHA will require a hearing protection program for workers.

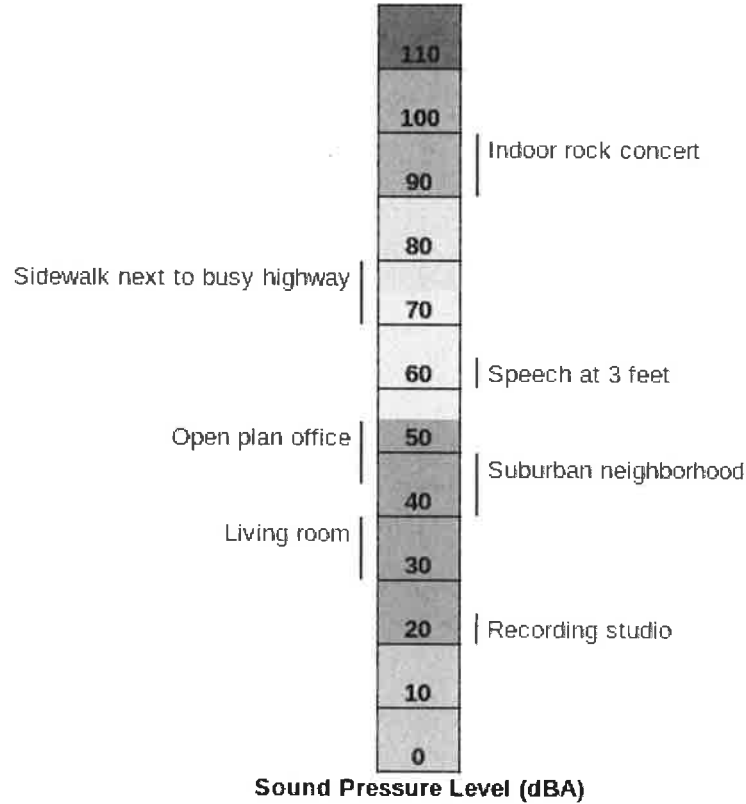

Figure 4.1. Sound Pressure Levels of Some Common Sources

4.1.2 Broadband Continuous Sound

A sound pressure level reading that does not change rapidly with time, does not contain tones, and covers a wide frequency range is said to be broadband with respect to frequency and continuous with respect to time. Broadband continuous sounds are characterized primarily by their sound pressure level. Common examples are fans, well pumps, and traffic noise.

Broadband continuous sounds are the simplest to quantify and are used as a point of comparison for other types of sound. That is, they provide a stable and relatively neutral basis for comparing tonal, impulsive, and other special sound classifications. The sound pressure level limits set in most noise regulations apply to this type of sound. Other sound classifications are adjusted so that their impact can be compared to a broadband continuous sound pressure level. This greatly simplifies noise regulations; however, it requires methodologies to be defined to accurately normalize sounds with special characteristics on the basis of community response to those characteristics.

4.2 Spectral Characteristics

The spectrum of an acoustic wave refers to its frequency content. The frequency range that a sound occupies may cover a wide band of frequencies, only a very narrow band, or even a single frequency in the case of a tone. Frequency is measured in units of Hertz (Hz) which are equivalent to one cycle per second.

4.2.1 Broadband

As described above, broadband means that the sound covers a broad spectrum of frequencies. This type of sound is in general the most neutral in terms of subjective sound quality. A broadband source with emphasis on the frequencies above 1,000 Hz may, however, be characterized as sharp or shrill.

4.2.2 Narrowband

Sounds occupying only a narrow portion of the auditory spectrum are said to be narrowband. Narrowband can be regarded as having a bandwidth less than 1/3 of an octave. This type of sound is sometimes encountered in impact processes where the impact excites a structural resonance, but the duration of the sound is very short due to damping in the structure. Narrowband sounds will require a sound pressure level adjustment due to their spectral characteristics in relation to broadband continuous sounds if they have tonal prominence (see Section 5.5.1 Assessing Tonal Sounds).

4.2.3 Tonal

Sounds containing pure tonal frequencies are usually produced by rotating machinery, but can also be electrically amplified signals such as those created by a backup alarm. Human hearing is sensitive to tones. Sounds having tonal prominence will require an adjustment in order to be compared to broadband continuous levels (see Section 5.5.1 Assessing Tonal Sounds).

4.2.4 Infrasound and Ultrasound

The nominal range of human hearing is 20 Hz to 20,000 Hz. Sounds outside this range are referred to as infrasound if below 20 Hz and ultrasound if above 20,000 Hz. Objectionable infrasound can sometimes be generated by wind turbines or industrial sound sources.

4.3 Temporal Characteristics

The way sound changes with time can have a significant influence on the noise impact. Accounting for these characteristics is important for accurately predicting community response.

4.3.1 Stationary or Continuous

Sound that changes slowly in amplitude with time is known as continuous or in statistical terms, stationary. In practice, sounds that do not meet the criteria for impulsive, rapid onset, or modulated are considered continuous and do not require any sound pressure level adjustment for

their temporal characteristics.

4.3.2 Impulsive

Impulsive sound is characterized by brief excursions of sound pressure whose peak pressure noticeably exceeds the continuous sound pressure. The duration of a single impulsive event is usually less than one second.

Impulsive sounds often create annoyance because they are similar to sounds that contain important information about our environment such as a sound outside the house or a door closing. We are sensitive to these types of sounds because they alert us to events occurring nearby that we may need to respond to. Continuous false alarms make it difficult to relax, concentrate, or sleep soundly without disturbance.

Many researchers have found that impulsive sound requires a level adjustment to properly account for the special characteristics and sensitivity to this class of sound [Buchta, Smoorenburg, Vos] and that listeners are able to differentiate between loudness and annoyance for sounds with temporal variance [Dittrich].

Impulsive sound is considered to have three subcategories: regular impulsive, highly impulsive, and high energy impulsive. Each of these categories has a different sound pressure level adjustment.

Highly Impulsive

Highly impulsive sound is characterized by a sudden onset and high degree of intrusiveness. This is common for impact processes and small arms fire. Highly impulsive sound in general has a duration too short to be accurately measured using maximum fast exponential time weighting. Impulses with a regular repetition rate greater than 20 Hertz may be perceived as tonal rather than impulsive and require a tonal level adjustment.

Research has indicated that highly impulsive sound should receive a 12 to 13 dB adjustment [Buchta, Smoorenburg]. ANSI S12.9 Part 4 and ISO 1996 Part 1 recommend a 12 dB adjustment.

High Energy Impulsive

High energy impulsive sound is usually produced by explosive sources where the equivalent mass of dynamite exceeds 25 grams. Common sources are blasting or artillery fire. Sonic booms not produced by small arms fire are also included in this subcategory. High energy impulsive sound differs from highly impulsive sound mainly in the amount of low frequency energy produced.

Regular Impulsive

Impulsive sound not categorized as high energy or highly impulsive is categorized as regular impulsive. ANSI S12.9 Part 4 and ISO 1996 Part 1 recommend a 5 dB adjustment for regular impulsive sound.

Modulated

Another type of transient sound is characterized by amplitude modulation. These sounds consist of a continuous series of impulsive events such as speech or music. Human hearing is most sensitive to amplitude modulation at a rate of about 4 Hz [Zwicker & Fastl, p. 177, 247-8]. This, not surprisingly, is the rate at which talkers typically produce syllables when speaking. Sounds having amplitude modulation near this rate may cause higher annoyance than continuous sounds at the same sound pressure level and should be treated as regular impulsive. When a large number of conversations is occurring at once such that the words of individual speakers cannot be understood, the noise impact may be more similar to a broadband continuous sound source.

4.3.3 Time of Occurrence

Sounds that occur at certain times may become more objectionable. The community noise impact of sounds that occur at night is higher than in the daytime. Community noise impact is also higher during times when people are normally at home than when they are normally away at work.

4.4 Ensemble and Background Sound Pressure Levels

Noise complaints usually involve a specific sound source. In any outdoor environment the source of interest will be among many background sources. Since it is in general not possible to remove the background sources, acoustical measurements must be performed in the presence of all active sound sources. “Ensemble sound pressure level” will refer to the sound produced by all sources at a given location including the source of interest. “Background sound pressure level” will refer to the sound present with the source of interest deactivated.

5. Measurement and Assessment of Environmental Sound

5.1 Quantification of Sound

5.1.1 Sound Pressure

The measurement of sound in regard to noise regulation focuses on the sound pressure level (SPL) as described in Section 4.1.1. The human ear is a pressure sensor; therefore, the SPL most directly relates to the community response to noise. The human sensation of hearing does not, however, work in the same way that a microphone does. Spectral and temporal characteristics of a sound source can have a significant effect on the community response to that source. Signal processing must be applied to the measured sound pressure in order to adjust the measurement to the actual sensitivities of human hearing.

5.1.2 Frequency Weighting

The first step in accurately representing the perceived loudness of sound is to simulate the frequency response of the human ear. Human hearing has lower sensitivity to sounds below 250 Hz and above 8,000 Hz as seen in Figure 5.1 [ISO 226]. Hearing sensitivity as a function of frequency is, however, also a function of amplitude. Different frequency weighting filters must therefore be used for different amplitude ranges. Figure 5.2 illustrates the A and C frequency weighting curves [ANSI S1.4] that simulate the equal loudness contours of human hearing with respect a 1,000 Hz tone at sound pressure levels of 40 and 100 dB respectively. Noise regulations generally specify the A-weighted sound pressure level since this curve most closely matches the target noise level goal for broadband sound sources.

A-weighted sound pressure levels are commonly expressed as dBA, dB(A), or L_A .

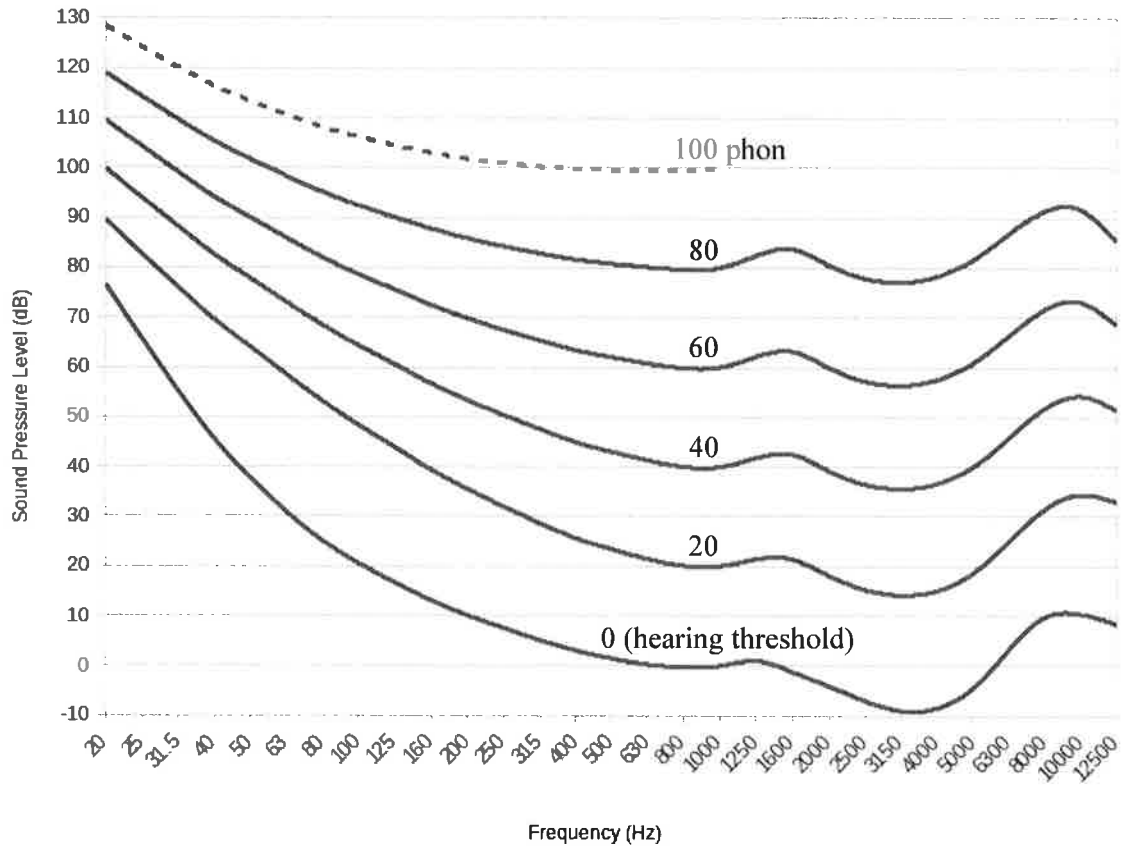

Figure 5.1. ISO 226 Equal Loudness Contours

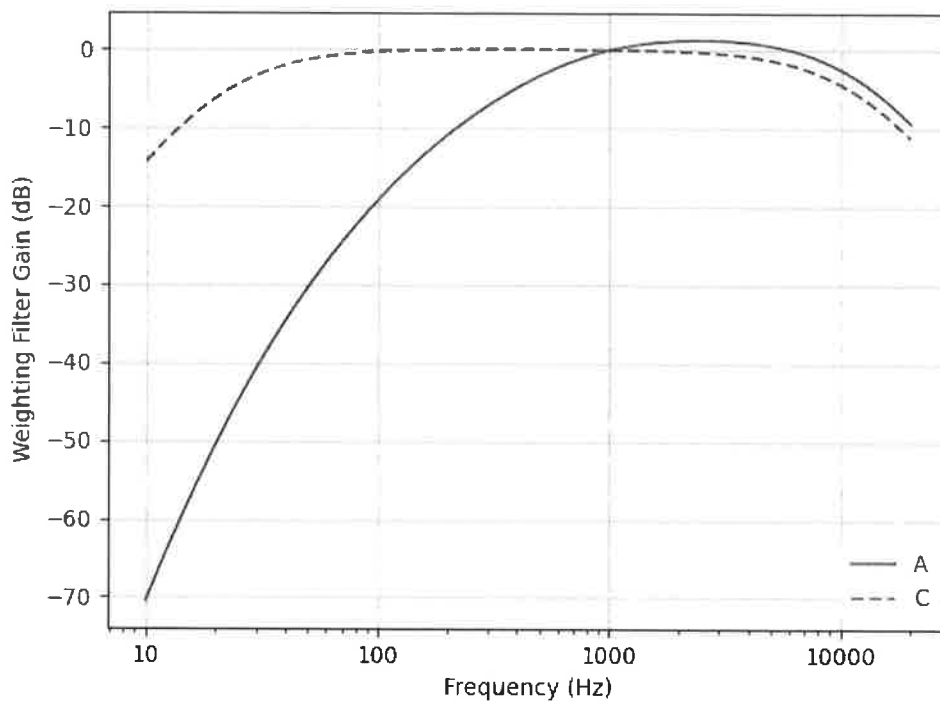

Figure 5.2. ANSI S1.4-2014 Frequency Weighting Curves

5.1.3 Equivalent-continuous Sound Pressure Level

The equivalent-continuous sound pressure level is the principal acoustical quantity measured for long term noise impact assessment. This is a root-mean-squared average of the sound pressure over a period of time expressed as a sound pressure level. Equivalent sound pressure levels may represent the average level over a period of minutes, an hour, or some other interval.

The A-weighted equivalent sound pressure level is represented as LA_{eq} . The equivalent-continuous sound pressure level does not use exponential time weighting (see below).

5.1.4 Day Night Level

A variation of the A-weighted equivalent sound pressure level is the day night level (DNL or L_{dn}). This metric incorporates the increased sensitivity to noise at night by adding a 10 dBA adjustment to sound occurring between 10:00 pm and 7:00 am. DNL is the most common metric used for transportation noise and is often applied to other broadband continuous sound sources.

5.1.5 Percentiles

To gain more insight into the noise environment during a long term measurement, some statistical quantities may be employed. The quantities LA_{10} and LA_{90} represent the A-weighted sound pressure level exceeded during 10% and 90% of the time of the measurement. LA_{90} is often used as an indication of the minimum background noise level without the presence of single noise events. LA_{10} indicates the highest sustained levels.

5.1.6 Sound Exposure Level

The sound exposure level (SEL) is used to quantify single noise events. It is particularly useful when the duration of an impulsive sound is too short to be accurately measured with an equivalent-continuous or exponential time weighted sound pressure level measurement. The equivalent-continuous level represents the mean squared average sound pressure. It does not account for instantaneous peak pressures. Impulses with short durations tend to get averaged out although the peak pressure may be significant. This can sometimes lead to the mistaken conclusion that the impulse has no greater noise impact than the background noise.

The sound exposure level also allows single noise events to be extracted from the measurement so that adjustments for special characteristics can be applied to more accurately represent the community response.

5.1.7 Peak Sound Pressure Level

For impulsive sounds with rapid onset, the instantaneous peak sound pressure level may be important. This metric may be used to supplement the sound exposure level for highly impulsive noise events that do not occur frequently enough to accumulate a substantial amount of sound energy, but nevertheless do present a significant noise impact due to their high peak pressure levels.

It should be noted that peak sound pressure level alone does not necessarily differentiate between intrusive highly impulsive and regular impulsive sounds. Different impulsive sound sources with the same peak sound pressure may have different noise impacts. Noise impact assessment of impulsive sound is often multidimensional involving onset rate, frequency range, and impulse duration.

5.2 Acoustical Instrumentation

5.2.1 The Sound Level Meter

In the regulation of community noise, a sound level meter (SLM) meeting prescribed standards for accuracy and conformity is used. The meter consists of a microphone and a signal processing unit that performs frequency weighting (usually A and C) and time weighting functions. The sound pressure level is displayed on the meter. An SLM that can log sound pressure levels and compute an equivalent-continuous level is called an integrating SLM. Modern SLMs incorporate digital signal processing capable of logging many acoustical metrics at the same time and can save simultaneous calibrated audio recordings for source confirmation and further analysis.

Most professional acousticians use, and many noise regulations require, a meter meeting the ANSI S1.4 Type 1 standard. This is the highest accuracy used for field work. Type 2 meters meet a lower standard of accuracy and are allowed by OSHA and some municipal codes.

5.2.2 Exponential Time Weighting

When taking sound pressure level measurements in the field, the reading on the meter can fluctuate rapidly for some sound sources. Exponential time weighting is a method of stabilizing the reading by applying a smoothing filter to the sound pressure envelop. Professional sound level meters will typically have three exponential time weighting settings: fast, slow, and impulse. The slow setting has time constant of 1 second. The fast setting time constant is 0.125 seconds (1/8 of a second). For most measurements the fast setting is preferred with the exception of impulsive sounds with a rapid onset rate.

Impulse time weighting uses a 0.035 second time constant on the rise of the sound pressure envelop with a peak hold having a 1.5 second time constant on the decay. The purpose of this setting is to allow a faster response on the rise of the signal to reduce the attenuation of the maximum pressure of the impulse, but have a slow decay to hold the reading on the meter display so it can be read and recorded. This time weighting is, however, still much slower than the impulse produced by typical highly impulsive sound source such as a pickleball paddle impact.

5.2.3 Integrating Sound Level Meters

Integrating SLMs integrate the sound pressure over the time period of a measurement in order to calculate the equivalent-continuous sound pressure level (LAeq). An integrating meter is required for noise regulations that specify metrics based on equivalent-continuous sound pressure level such as the day night level (DNL) or hourly sound pressure level.

5.2.4 Frequency Band Analysis

Some sound level meters include filters for obtaining octave band and fractional octave band sound pressure levels. Frequency band data is needed for designing sound walls and other noise abatement treatments. Unweighted octave band sound pressure levels may also be used to assess low frequency sound in regard to acoustically induced vibration caused by air handling units or subwoofers.

5.2.5 Calibration

The calibration of the sound level meter should be recertified by a qualified, independent metrology laboratory at intervals recommended by the manufacturer of the meter, usually one year. The sound level meter shall be used as provided in the manufacturer's instructions.

It is standard practice when carrying out sound pressure level measurements to place a calibration device recommended by the meter manufacturer over the microphone before and after testing to verify that the sensitivity of the microphone has not changed and that the equipment has not been damaged prior to or during testing. The field calibrator should also be sent to a

qualified metrology laboratory to have the calibration certified at intervals specified by the equipment manufacturer. This period is usually one year.

5.3 Calculation Methods

5.3.1 Decibel Addition

When working with multiple sound sources, it may be necessary to understand how each individual source contributes to the total sound pressure level. Decibel levels do not add arithmetically, but must be combined logarithmically. Figure 5.3 shows a chart for adding two levels. First, calculate the difference in the levels. Next, find the level difference on the horizontal axis of Figure 5.3 and find the corresponding level addition of the vertical axis. Add this number to the highest of the two levels. For example, to add two levels, 50 and 56 dB, together, find the difference, 6 dB, on the chart. The addition is 1 dB. Therefore, the decibel sum of 50 and 56 dB is 57 dB. If the level difference is greater than 10 dB, the contribution of the lower level source is negligible.

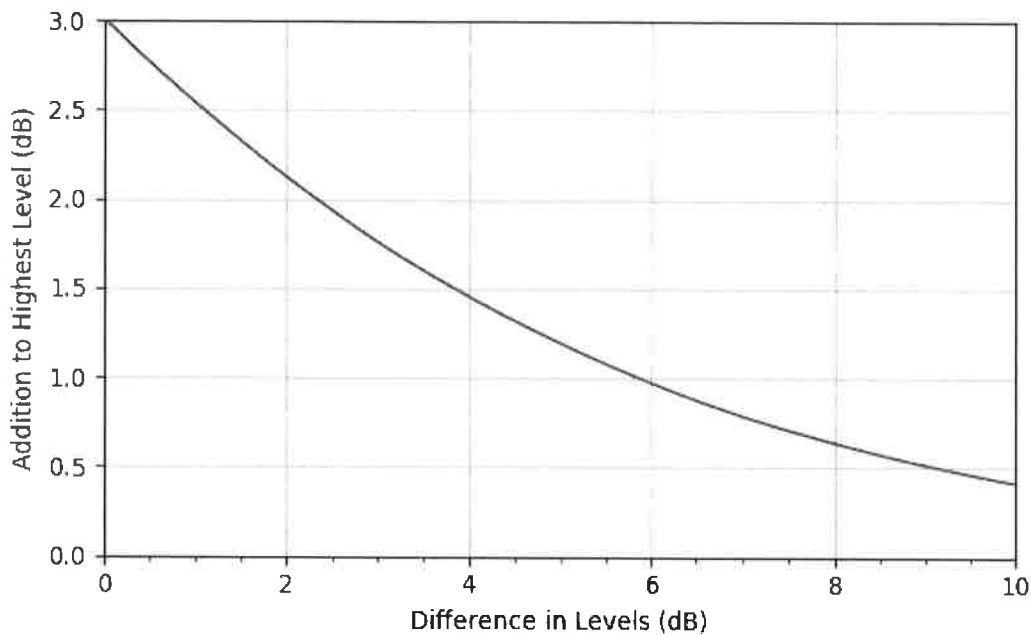

Figure 5.3. Decibel Addition

Equation 5.1 gives the direct calculation for the decibel sum, L_s , of levels, L_1 and L_2 .

$$L_S = 10 \log_{10} (10^{0.1L_1} + 10^{0.1L_2}) \quad (5.1.1)$$

5.3.2 Background Noise Correction

When assessing a noise issue it is common to measure the sound source of interest in the presence of other background sources. If the background noise level is within 10 dB of the ensemble noise level (see Section 4.4) a background noise correction should be applied to avoid overestimating the sound pressure level produced by the source of interest.

The corrected source level, L_{Source} , is found by the decibel subtraction of the background noise level, L_{bgn} , from the ensemble level, L_{ens} .

$$L_{Source} = 10 \log_{10} (10^{0.1L_{ens}} - 10^{0.1L_{bgn}}) \quad (5.2)$$

The background corrected sound pressure level of the source can also be found using Figure 5.4. Subtract the background sound pressure level from the ensemble level. Find this level difference on the horizontal axis of the figure and locate the corresponding decibel value on the vertical axis. Subtract this number from the ensemble sound pressure level to get the background corrected level of the source.

If the ensemble sound pressure level is within 3 dB of the background noise level, the source of interest is producing less sound pressure than the background sources and cannot be accurately assessed. When the conditions on the site prevent the background sound pressure level from being measured it should be noted in the measurement report.

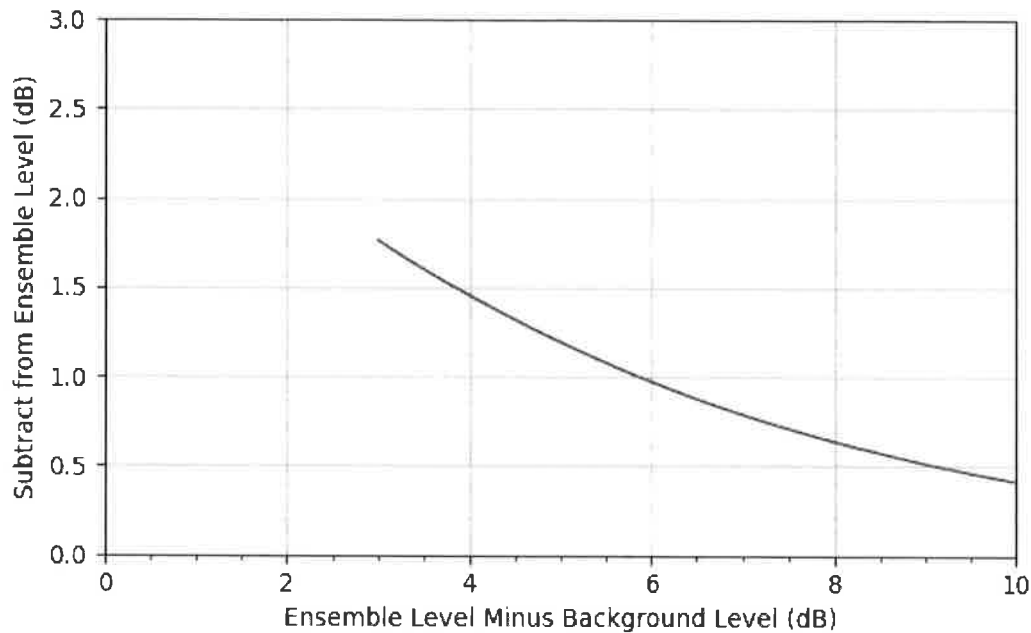

Figure 5.4. Background Noise Correction

Example:

An exhaust fan located on the exterior wall of a warehouse building runs continuously. A sound pressure level measurement taken at the nearest residential property line with the fan running reads 64 dBA. The fan is then shut off and the measurement repeated. The sound pressure level now reads 58 dBA due to a nearby roadway.

Subtracting the background noise level (58 dBA) from the ensemble level (64 dBA), which includes the fan and all other sound sources in the area, gives a difference of 6 dBA. From Figure 5.4, a 6 dB level difference on the horizontal axis corresponds to 1.0 dB on the vertical axis. Subtracting this number from the ensemble sound pressure level gives a result of 63 dBA for the sound pressure level of the exhaust fan by itself.

5.4 Measurement Procedures

5.4.1 Field Calibration

The calibration of the sound level meter shall be recorded before and after each series of measurements using a field calibrator or method recommended by the manufacturer of the meter.

5.4.2 Measurement Conditions

To the extent practical, all sound sources contributing to the ensemble sound pressure level at the point of measurement should be identified.

Measurements should not be performed when wind speeds exceed 10 knots (11 miles per hour, 5 meters per second), the SLM may become wet, or temperatures are outside the tolerance range of the SLM as specified by the manufacturer. A properly fitted windscreen shall be attached to the microphone.

Unless necessary, hourly or shorter duration measurements at distances greater than 100 feet (30 meters) should be performed on sunny days in order to avoid acoustic shadow zones formed by thermal inversions caused by ground heating. When the sun heats the ground, the relatively warm layer of air near the ground can cause sound to refract upward creating a complete or partial shadow. Measurements taken in the shadow zone can underestimate the sound pressure levels present at other times of the day.

5.4.3 Measurement Locations

The preferred noise assessment location is at the property line of the receiving property at the point most impacted by the sound source in question. More than one measurement location may be necessary for multiple sound sources or some noise sensitive areas.

In some situations the area most affected by the sound source of interest may be inside the boundaries of the receiving property. This is sometimes the case, for example, if there is a wall blocking sound at the property line. Measuring the sound directly behind the wall may not be representative of the sound levels farther from the wall inside the receiving property or at the upper floors of a building located on the property.

5.4.4 Sound Level Meter Placement

The microphone of the sound level meter should be placed at a minimum height of 45 inches (1.1 meters) above ground level and a minimum distance of 12 feet (3.6 meters) from any other reflecting surface. The microphone should not be placed closer than 12 feet (3.6 meters) from any sound source.

Other microphone placements may be used as necessary to assess a specific noise sensitive area, but their acoustical characteristics must be specified.

5.4.5 One Hour Equivalent-continuous Sound Pressure Level Measurements

One hour equivalent-continuous sound pressure level measurements shall be conducted using an integrating sound level meter. For sound sources that do not change in level over time, a shorter measurement period may be used provided the sound pressure level measured is typical of the source in question, but not less than 2 minutes. If a sound source has a regular operating cycle, the time period of the operating cycle, including both time on and time off, may be used for the measurement.

5.5 Adjusted Sound Pressure Levels

Sound sources that have special characteristics including impulsiveness and tonality have been found to have a noise impact greater than that indicated by the equivalent-continuous level. To account for this a set of adjustments to the equivalent-continuous sound pressure level have been defined based on the recommendations of ANSI S12.9 Part 4. These adjustments apply to equivalent-continuous sound pressure level measurement such as one hour A-weighted sound pressure levels (LAeq) and octave band equivalent-continuous sound pressure levels.

5.5.1 Assessing Tonal Sounds

Sounds having tonal prominence receive a 5 dB adjustment. Tonal prominence is determined according to ANSI S12.9 Part 4 Annex C by comparing adjacent unweighted one-third octave band equivalent-continuous sound pressure levels to the one-third octave band containing the tonal frequency. If the adjacent band level differences are greater than 15 dB for the 25 to 125 Hz bands, 8 dB for the 160 to 400 Hz bands, or 5 dB for the 500 to 10,000 Hz bands, the tone has prominence and a tonal adjustment shall be applied to the one-third octave band containing the tonal component.

Tonal prominence may also be determined using the narrowband methods in ANSI S1.13-2005 Annex A. This method may be necessary for tones that are close to the separation between two one-third octave bands resulting in bleed over into both bands.

5.5.2 Assessing Impulsive Sounds

Two categories of impulsive sound are addressed in this document: regular impulsive and highly impulsive.

Regular impulsive sound includes speech and music. It receives a 5 dB adjustment.

Highly impulsive sounds receive a 12 dB adjustment. Highly impulsive sounds occurring at a rate greater than 20 per second are usually not perceived as distinct impulses and no impulse adjustment shall apply; however, if the repetitions are regular in time a tonal sound adjustment may be necessary.

Equivalent-continuous sound pressure level alone is not sufficient to assess sounds characterized by impulsiveness. Highly impulsive and sporadic single events may produce a relatively small amount of energy compared to the background noise level. This does not necessarily mean they will not have a significant impact. Equivalent-continuous levels are often insensitive to short duration events even though the impulses may be clearly noticeable. In these instances the sound exposure method may be necessary to assess these events (see Section 5.5.3).

5.5.3 Applying Adjustments Using Sound Exposure Level

Impulsive sounds are usually spread out in time whereas background noise is continuous. The background noise will therefore often contribute more to an energy averaging metric like the equivalent-continuous sound pressure level than the impulses even though an observer on the site may report the impulses as the primary sound source due to their high peak sound pressures. In

cases like this a windowing method such the sound exposure must be used to separate the impulses from the background noise so that adjustments can be appropriately applied to the part of the ensemble sound containing the impulses.

One common use for the sound exposure level (SEL) is the comparison of two discrete sound events; however, in the context of applying adjustments to impulsive sound the SEL will be used to overcome the influence of the background noise by separating out the individual impulse events from the rest of the measurement data. The SEL of a single event, SEL_{event} , can be found from the background noise corrected equivalent-continuous sound pressure level over just the time of the event, $L_{eq,event}$,

$$SEL_{event} = L_{eq,event} + 10 \log_{10}(T_{event}/T_0) \quad (5.3)$$

where T_{event} is the duration of the event in seconds and T_0 is the reference time of 1 second. T_{event} should be inclusive of the entire event. In situations where the background noise level fluctuates it may be necessary to find the background noise level in the immediate vicinity of each impulse event in order to do the corrections.

The appropriate regular or highly impulsive adjustment can now be added directly to the SEL of the event. This process can be repeated for each impulse to obtain a set of SELs.

In order to compare the resulting sound exposures to the level limits in the regulations, the SELs must be converted to an equivalent-continuous level over the time period of the original measurement. The adjusted equivalent-continuous level of the impulses during the time of the measurement, $L_{eq,adj}$, is therefore the decibel sum of each event's background corrected sound exposure level, $SEL_{event,i}$, and its adjustment, K_i , minus the measurement time, T , in decibels.

$$L_{eq,adj} = \sum_i 10^{(0.1(SEL_{event,i} + K_i))} - 10 \log_{10}(T/T_0) \quad (5.4)$$

An alternative form of Eq. 5.4 is useful in when the mean SEL and the number of events over a period of time are known for an impulsive sound source.

$$L_{eq,adj} = SEL_{src} + K_{impulse} + 10 \log_{10}(N) - 10 \log_{10}(T/T_0) \quad (5.5)$$

Here $L_{eq,adj}$ is equal to the sum of the sound exposure level for one event occurrence, SEL_{src} , the adjustment for the type of impulse, $K_{impulse}$, the number of occurrences, N , in decibels, and total time period over which the impulses occur, T , in decibels.

$L_{eq,adj}$ can now be combined with the other adjusted sound source levels in the project using Eq.

5.1 to obtain the total adjusted equivalent-continuous sound pressure level. This level can then be compared to the level limits in the noise regulations.

For more information on sound exposure level see ANSI S12.9 Part 4 and Harris, Chapter 12.

5.5.4 Time of Day Adjustments

For noise impact assessment, the day is typically divided into three segments: day, evening, and night. For residential land uses, each of these time periods will have different noise sensitivities. During the daytime, usually defined as 7:00 am to 7:00 pm, many people are at work or busy with other activities away from home. In the evening, 7:00 pm to 10:00 pm, people tend to be at home and are more aware of noise in the area. Nighttime is the most noise sensitive time as people are sleeping. Weekends also have a higher noise sensitivity similar to evenings when people tend to be at home, but not sleeping.

For residential land uses, time of day adjustments include a 5 dB adjustment for the evening and a 10 dB adjustment for the nighttime hours. Weekend daytime hours also receive a 5 dB adjustment similar to evening hours.

5.6 Measurement Reports

After a set of field measurements have been completed, a report of the findings should be issued containing the following information:

1. Make, model, and serial number of each piece of measuring equipment
2. Date and location of the most recent laboratory calibrations
3. Site plan showing measurement locations
4. Statement of on-site calibration verification before and after each series of measurements
5. Name of the engineer conducting the tests

For each measurement location the following information should be noted:

1. Date and time of the measurement
2. Acoustical metrics measured
3. Time and frequency weighting used
4. Microphone location and height
5. Windscreen used
6. Description of the test location including the type of ground and any reflecting surfaces near the SLM or sound source being investigated
7. Primary and secondary sound sources contributing to the measurement

8. Background noise level if investigating a specific sound source
9. Weather conditions: temperature, humidity, wind speed and direction, cloud cover, and sun exposure
10. Photo image showing the sound level meter and intervening ground between the meter and the sound source of interest

5.7 Noise Impact Assessments

5.7.1 Purpose and Methods

A noise impact assessment provides a determination of the likely effects of introducing a new activity on the surrounding area. For new developments or modifications of existing developments involving on site activities that are likely to have a noise impact on the surrounding area, a noise impact assessment should be prepared by a qualified acoustical engineer. ISO 9613 and ANSI S12.62 provide a basic methodology for predictive acoustical site assessment; however, other methodologies may be used as appropriate for the area, conditions, and sound sources being evaluated. A noise impact assessment may be based on measurements of similar sound sources at a different location; however, differences in propagation paths that may affect the noise impact must be accounted for.

5.7.2 Present and Future Noise Exposure

With many sound sources, the noise impact may increase over time, e.g. roadways and other modes of transportation whose usage can be expected to increase in the future. In preparing noise impact assessments for proposed developments, future usage patterns should be included in the analysis.

5.8 Existing Noise Regulations

Best practices and current standards for noise assessment have been covered in Chapter 3. These criteria will be used here to evaluate noise regulations that apply within the City of Centennial.

5.8.1 City of Centennial Municipal Code, Chapter 10, Article 12

The City of Centennial does not currently have a land use noise regulation. Noise violations are defined in the Municipal Code. Two sections of the Code relate to noise assessment.

Sec. 10-12-10. - Legislative declaration.

It is hereby declared that protection and preservation of the home is of the highest importance; that unnecessary and excessive noise is a significant source of environmental pollution that threatens the public health, welfare, tranquility and good order of the community; and that the prohibitions and other protections set forth in this Article are enacted to secure and promote public peace, welfare, comfort and health.

Sec. 10-12-20. - General prohibition.

It shall be unlawful for any person to make, continue or cause to be made or continued any excessive or unusually loud noise which:

- (1) Disturbs, annoys or endangers the peace, repose, comfort, safety or health of others; or
- (2) Endangers or injures personal or real property.

These Code sections do not prescribe an objective measure of excessive noise, but state that “protection and preservation of the home is of the highest importance.” Section 10-12-20(1) prohibits sound that “disturbs, annoys or endangers the peace, repose, comfort, safety or health of others.” No guidance is given for compliance with the Code; however, ANSI S12.9 Part 4 is a standard for assessing annoyance in a community setting caused by noise and would be in alignment, as an objective assessment methodology, with the criteria in Section 10-12-20(1).

5.8.2 Colorado Revised Statues 25-12-101

The Colorado Revised Statues seeks to provide statewide minimum standards for noise levels.

25-12-101. Legislative declaration

The general assembly finds and declares that noise is a major source of environmental pollution which represents a threat to the serenity and quality of life in the state of Colorado. Excess noise often has an adverse physiological and psychological effect on human beings, thus contributing to an economic loss to the community. Accordingly, it is the policy of the general assembly to establish statewide standards for noise level limits for various time periods and areas. Noise in excess of the limits provided in this article constitutes a public nuisance.

C.R.S. 25-12-103(1) provides some objective maximum limits on permissible sound pressure levels. For residential land uses, the daytime limit is 55 dBA. Evening hours are not defined; however, nighttime hours are from 7:00 pm to 7:00 am. This includes hours that would normally be considered evening. The nighttime sound pressure level limit is 50 dBA which is more typical of a 5 dBA evening penalty than the more customary 10 dBA nighttime level limit reduction.

Acoustical measurements are to be made 25 feet inside the receiving property boundary. This is problematic for a number of reasons. First, it requires entering private property in order to assess the sound level. This makes assessment, monitoring, and enforcement more difficult. It also does not protect the entire receiving property. This can be especially impactful for residents on small lots or rental properties where the back patio may be within this distance.

While C.R.S. 25-12-103(3) does include provisions for impulsive sound,

Periodic, impulsive, or shrill noises shall be considered a public nuisance when such noises are at a sound level of five db(A) less than those listed in subsection (1) of this section.

with a 5 dBA reduction in the allowable sound pressure level, this approach is overly simplistic

and will underestimate the noise impact of highly impulsive sounds.

Overall, the noise assessment procedure in C.R.S. 25-12 appears to be a compromise between simplicity of noise assessment and completeness. While adequate for many sound sources, it will underestimate the noise impact some classifications of sound that include highly impulsive sound and sounds that occur during regular nighttime hours of 10:pm to 7:00 am when most residents are sleeping. The choice of noise assessment location 25 feet inside the receiving property increases the difficulty of monitoring and decreases the level of protection afforded to home owners for the use of their outdoor spaces.

6. Characteristics of Pickleball Sound

Spendiarian & Willis has prepared many noise assessments and abatement plans for pickleball courts. This chapter summarizes some of the knowledge gained over the years of working with this sound source.

The main concern in regard to noise from the pickleball courts is the sound produced by the impact of the hard plastic ball on the paddles. This sound is characterized by a sudden onset and brief duration, thus classifying it as impulsive sound. The spectral content of the paddle impact is narrowband with a center frequency typically between 1,000 and 2,000 Hertz. This is near the most sensitive frequency range of human hearing.

6.1 Comparison of Pickleball to Other Activities

There is a common misconception that pickleball is acoustically equivalent to tennis, volleyball, or many of the other activities typically found at outdoor recreation centers and parks. Numerous news articles covering disputes over pickleball noise, many of which originate when existing tennis courts are converted to pickleball, demonstrate that this is not the case:

- Cutler, Amy, "Rise of pickleball pitting neighbor against neighbor, leading to lawsuits," *Arizona's Family*, Phoenix, Arizona. February 13, 2023. <https://www.azfamily.com/2023/02/13/rise-pickleball-pitting-neighbor-against-neighbor-leading-lawsuits/>
- Arden, Amanda, "Lake Oswego shuts down city pickleball courts indefinitely due to noise complaints." *KION 6 News*, Portland, Oregon. January 23, 2023. <https://www.koin.com/local/lake-oswego-shuts-down-city-pickleball-courts-indefinitely-due-to-noise-complaints/>
- Columbo, Mike, "Pickleball plan pits Kirkwood residents against neighboring country club." *Fox 2 Now*, Saint Louis, Missouri. January 26, 2023. <https://fox2now.com/news/contact-2/pickleball-plan-pits-kirkwood-residents-against-neighboring-country-club/>
- Sheets, Connor, "Pickleball noise is fueling neighborhood drama from coast to coast." *Los Angeles Times*, Los Angeles, California. March 3, 2022. <https://www.latimes.com/california/story/2022-03-03/pickleball-noise-fueling-neighborhood-drama>
- Adler, Erin, "Apple Valley neighbors in a pickle over pickleball noise." *Star Tribune*, Minneapolis, Minnesota. March 27, 2019. <http://www.startribune.com/apple-valley-neighbors-in-a-pickle-over-pickleball-noise/507726242/>
- Bartel, Mario, "Pickleball banished from Port Moody court after neighbours complain of

rising stress, anxiety.” The Tri-City News, Coquitlam, British Columbia, Canada. April 24, 2021. <<https://www.tricitynews.com/local-sports/these-games-are-loud-port-moody-pickleball-neighbours-revolt-against-rising-stress-anxiety-3662369>>

- City of Lakewood, “Green Mountain Courts Closure.” <https://www.lakewoodtogether.org/pickleball/news_feed/green-mountain-courts-update>
- Higgins, Sean, “No vote on residential pickleball until city adopts new land management code.” KPCW News, Park City, Utah. January 27, 2022. <<https://www.kpcw.org/park-city/2022-01-27/no-vote-on-residential-pickleball-until-city-adopts-new-land-management-code>>
- Maryniak, Paul, “Pickleball lights plan puts two HOAs at loggerheads.” Ahwatukee Foothills News, Tempe, Arizona. November 29, 2017. <https://www.ahwatukee.com/news/article_9056a946-d48e-11e7-9838-8b69fb2d50b2.html>
- Bottemiller, Kitty, “Too loud! Pickleball noise upsets neighbors.” Green Valley News, Green Valley, Arizona. August 28, 2013. <https://www.gvnews.com/news/local/too-loud-pickleball-noise-upsets-neighbors/article_542c2aac-0f91-11e3-acdc-0019bb2963f4.html>
- Clay, Joanna, “Woman sues Newport Beach over pickleball noise at park near her home.” Orange County Register, California. April 7, 2016. <<https://www.ocregister.com/2016/04/07/woman-sues-newport-beach-over-pickleball-noise-at-park-near-her-home/>>
- Wheatley, Mike, “Noisy pickleball courts cause upset with homeowners.” Realty Biz News. March 15, 2022. <<https://realtybiznews.com/noisy-pickleball-courts-cause-upset-with-homeowners/98768719/#:~:text=In one lawsuit in Newport Beach%2C Calif.%2C a.are causing them less enjoyment of their home.>>>
- Lazaruk, Susan, “Pickleballers face off with residents over noise in Metro Vancouver.” Vancouver Sun, Toronto, Ontario, Canada. February 2, 2022. <<https://vancouversun.com/news/local-news/pickleballers-face-off-with-residents-over-noise-in-metro-vancouver>>
- Shanes, Alexis, “Village in a pickle: How Ridgewood plans to tone down the pickleball court noise.” northjersey.com, California. January 16, 2020. <<https://www.northjersey.com/story/news/bergen/ridgewood/2020/01/16/ridgewood-nj-pickleball-noise-reduction-measures/4480463002/>>
- Monterey Herald Staff, “Pickleball noise controversy goes before city leaders Pacific Grove neighbors object to game at nearby tennis courts.” The Mercury News, California. September 19, 2019. <<https://www.mercurynews.com/2019/09/19/pickleball-noise-controversy-goes-before-city-leaders/>>
- Fraser, Patrick and Rodriguez, Ambar, “What to do about constant pickleball noise?” WSVN 7 News Miami, Miami, Florida. March 27, 2019. <<https://wsvn.com/news/help-me-howard/what-to-do-about-constant-pickleball-noise/>>

- Sutphin, Daniel, “Nixing the noise: Sound fence construction underway at Gilchrist pickleball courts.” Port Charlotte Sun, Charlotte Harbor, Florida. May 20, 2019. https://www.yoursun.com/charlotte/news/nixing-the-noise-sound-fence-construction-underway-at-gilchrist-pickleball/article_79a764de-7b1c-11e9-b4d4-6bcaa919f3f3.html
- Corrigan, James, “York residents complain noise from pickleball club is hurting quality of life.” WMTW News 8, Portland, Maine. November 16, 2021. <https://www.wmtw.com/article/york-residents-complain-noise-from-pickleball-club-is-hurting-quality-of-life/38271921>

It should be clear from the above list of references that pickleball constitutes a significant change in the acoustic environment of the area surrounding the courts in comparison to tennis and must be planned for accordingly. In particular, the impulsive sound produced by the impact of the hard plastic ball on the paddle can cause significant noise impact for those living near the courts.

6.2 Effects of Impulsive Sound

Persistent impulsive sounds create annoyance because they are similar to sounds that contain important information about our environment such as footsteps, a door opening, a tap at the window, or speech. We are sensitive to these types of sounds because they alert us to events occurring nearby that we may need to respond to. Continuous false alarms such as the popping sound created by pickleball paddle impacts make it difficult to relax, concentrate, or sleep soundly without disturbance as each time a pop is heard it draws the attention, creating distraction.

6.3 Acoustical Characteristics

The sound produced by the impact between a pickleball and paddle is characterized by a rapid onset and brief duration, typically on the order of 2 to 10 milliseconds (0.002 to 0.010 seconds) for the direct path sound. This classifies it as impulsive sound. Figure 6.1 shows a time trace of a pickleball paddle impact measured near Phoenix, Arizona. The main part of the direct sound impulse can be seen to be less than two milliseconds followed by a rapid decay and some later reverberant arrivals.

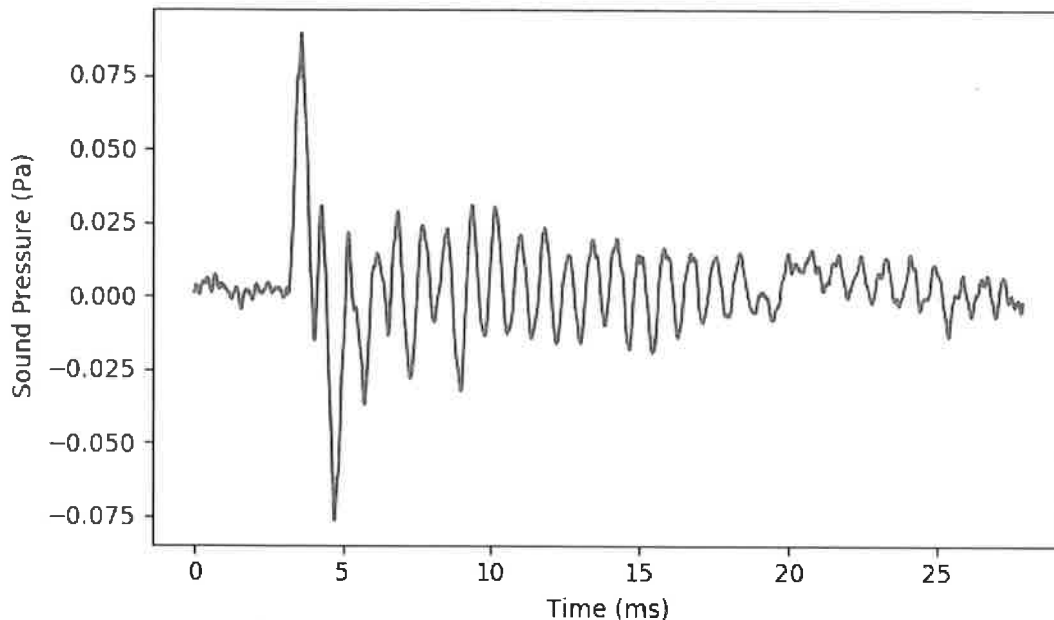

Figure 6.1. Pickleball Paddle and Ball Impact Sound Pressure Trace
1 millisecond (ms) = 0.001 seconds.

The spectral content of the paddle impact is narrowband with a center frequency typically near 1,000 Hz (see Figure 6.2). Although it does not meet most guidelines for tonal prominence such as Annex C of ANSI S12.9 Part 4 or ANSI S1.13, it does impart a vague sensation of pitch similar to a wood block percussion musical instrument. The radiation pattern of the paddle is more or less a dipole, i.e. the sound from the front and back of the paddle is of opposite polarity and cancels itself in the plane of the paddle. Therefore, orienting the courts so that the direction of play faces away from noise sensitive areas can provide some attenuation.

The sound power spectrum of the pickleball and paddle impact has two basic shapes depending on how the ball is hit. Figure 6.2 and Figure 6.3 show the power spectra of a 'sharp' hit and a 'dull' hit. The curves are not calibrated for absolute level, but can be compared relatively.

The sharp hit spectrum shows a narrowband signature. The frequency of the peak typically varies between 1,000 and 2,000 Hz. The energy in the dull hit is more spread out, but still peaks between 1,000 and 2,000 Hz.

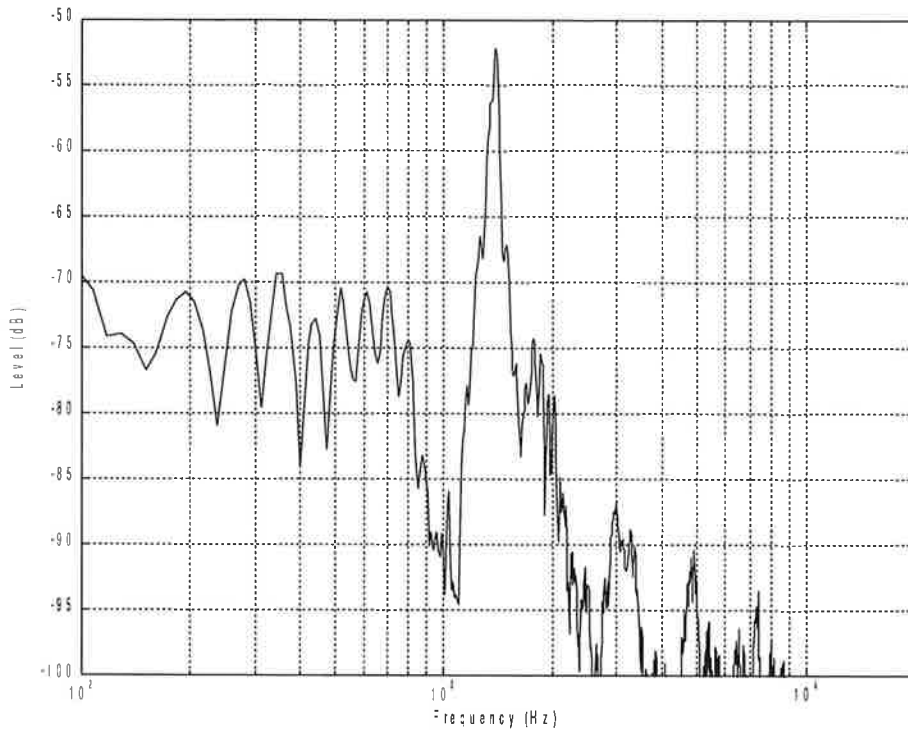

Figure 6.2. Spectral Response of a Sharp Hit

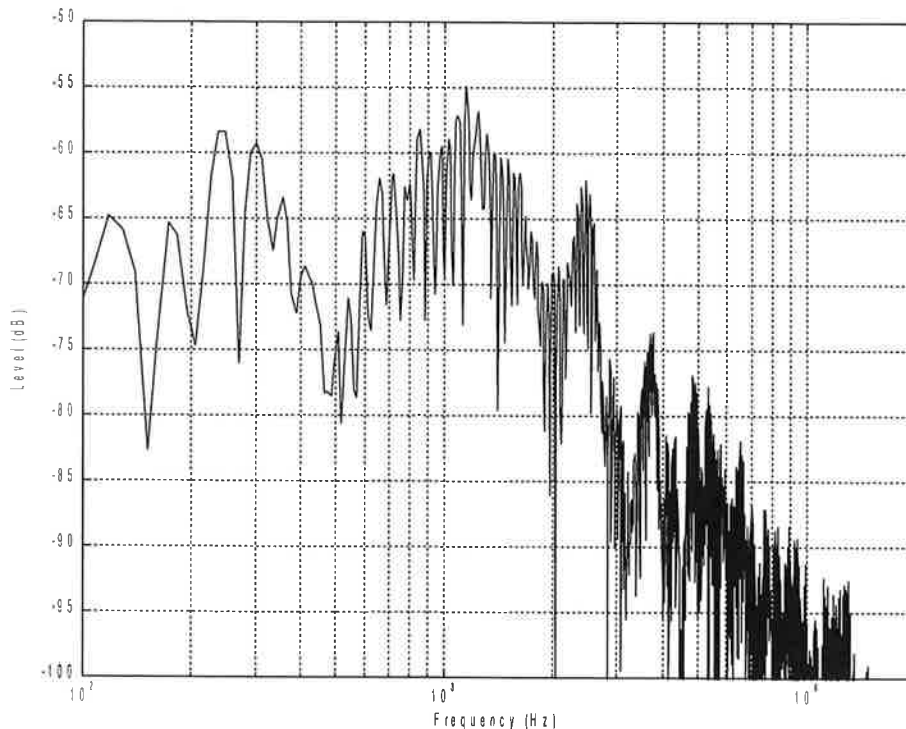

Figure 6.3. Spectral Response of a Dull Hit

A sound wall design will require effective attenuation in the 1,000 Hz octave band and above. In most applications, any material having a sound transmission class meeting STC 20 can be used to construct a sound wall or fence for pickleball provided best practices for sound barrier construction are followed.

6.4 Directivity of Pickleball Courts

The impulsive sound of the paddle impacts is radiated mainly by the large, flat paddle surface. Since both faces of the paddle are connected internally by a honeycomb structure and move together in vibration, one side of the paddle will produce a positive sound pressure while the other produces a negative sound pressure similar to a loudspeaker diaphragm that is not mounted in a cabinet. The result is that these two pressure waves having opposite polarity will cancel in the plane of the paddle where the path length from each face is the same to all receiver locations. This is known as a dipole or figure eight radiation pattern.

The positions of the paddles relative to the court change with each hit; however, the object of the game is to hit the ball to the opposite half of the court. Therefore, the dipole axis of each paddle impact will be in the general direction of play and not completely random. Measurements of

several pickleball facilities have shown that this results in a null depth of 4 to 5 dB. Figure 6.4 compares a typical pickleball court directivity pattern to a mathematical dipole where 0° and 180° are in the direction of play and the null is on the 90° and 270° bearings. Several decibels of attenuation can often be obtained simply by optimizing the orientation of the courts with respect to noise sensitive areas.

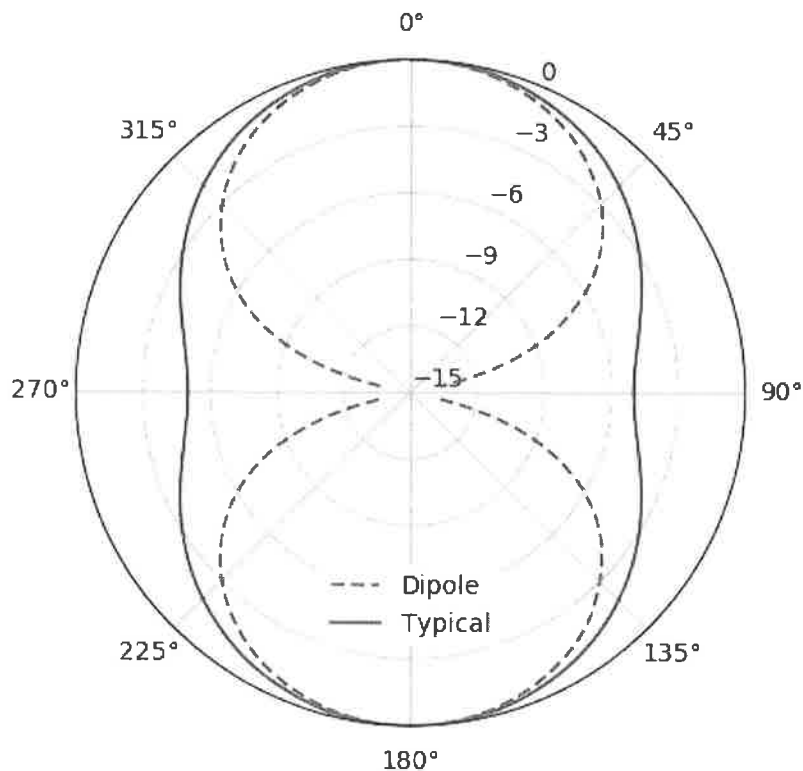

Figure 6.4. Typical Pickleball Court Directivity in Decibels

6.5 Noise Impact of Speech

In addition to the paddle impacts, speech is also a sound source on pickleball courts. While there are standards for speech sound power levels at various degrees of vocal effort such as ANSI S3.5, sound from speech emitted from pickleball courts can vary greatly with who is playing on the courts at a given time and be difficult to predict. In practice, noise abatement treatments sufficient to mitigate the paddle impacts should also be sufficient for speech from the courts as the paddle impacts typically have a greater noise impact.

Most noise objections regarding speech on pickleball courts are related to the content of the speech rather than the loudness. While the sound level of the speech can be reduced through abatement treatments, it cannot be made inaudible in most situations. A noise impact of this type must be addressed through court usage policy.

For tournament play, the overall speech pattern becomes more predictable. There are more sound sources that will approach a statistical average such as that described in ANSI S3.5. A total sound power level for the bleachers or spectator area can be calculated based on seating capacity or through direct measurement during a tournament.

7. Influence of Environmental Factors

7.1 Number and Arrangement of Pickleball Courts

Pickleball courts are usually placed on a rectangular concrete pad approximately 30 by 60 feet. This is one quarter the size of a typical tennis court pad such that a tennis court can be converted into four pickleball courts. An important factor influencing the amount of sound reaching neighboring properties will be the number of pickleball courts. A doubling of the number of courts will result in a doubling of the number of sound sources and therefore the sound power emitted. This corresponds to a 3 dB increase in sound power level. Pickleball courts are, however, not a single sound source, but a distribution of many sound sources spread over the area of the courts. For this reason, sound radiated from pickleball courts will not follow the inverse square law unless the distance from the center of the courts to the point of observation is large compared to the dimensions of the court or group of courts.

Figure 7.1 shows the ANSI S12.9 adjusted sound pressure level contours (see Section 8.3.3) at a height of 5 feet above grade for four courts, indicated by the red box, at the center of the main group of pickleball courts. For reference, the two groups of eight courts together have a width east to west of 136 feet and a length north to south of 268 feet. The oblong shape of the contours is not a result of the rectangular layout of the courts, but the directivity of the individual courts themselves (see Section 6.4).

The 55 dBA contour extends about 480 feet from the courts in the direction of play and 260 feet laterally. Figure 7.2 expands the number of pickleball courts to eight arranged in pairs end to end. The 55 dBA contour extends about 630 feet from the courts in the direction of play and 350 feet laterally. Figure 7.3 rearranges the eight courts into two rows side by side. The 55 dBA contour extends about 685 feet from the courts in the direction of play and 340 feet laterally. Doubling the number of courts causes the 55 dBA contour to move out 30% to 40% of the distance from the courts pad (red boxes) depending on how the courts are arranged.

The hypothetical examples above were created on level ground with a mixed ground type outside of the concrete pads for the courts (ISO 9613 ground factor, $G = 0.5$). In practice, noise complaints about pickleball courts at distances greater than 500 to 600 feet are rare. Real pickleball sites will usually have topographical features that hinder sound propagation at farther distances as well as structures that block or scatter sound. Pickleball courts across water may be an exception with the possibility of complaints occurring at distances approaching 800 to 1,000 feet.

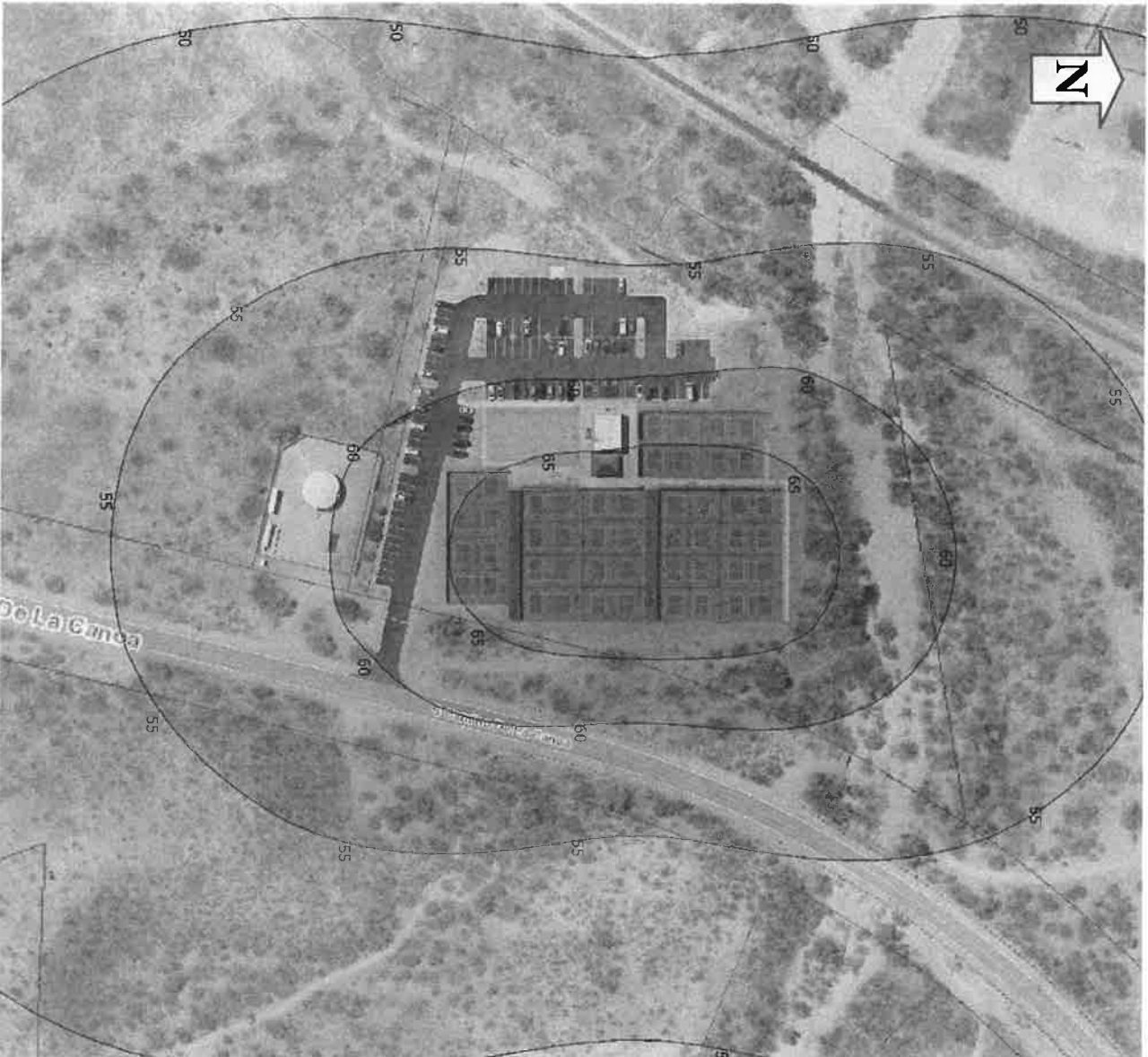

Figure 7.1. Adjusted Sound Pressure Level from Four Pickleball Courts

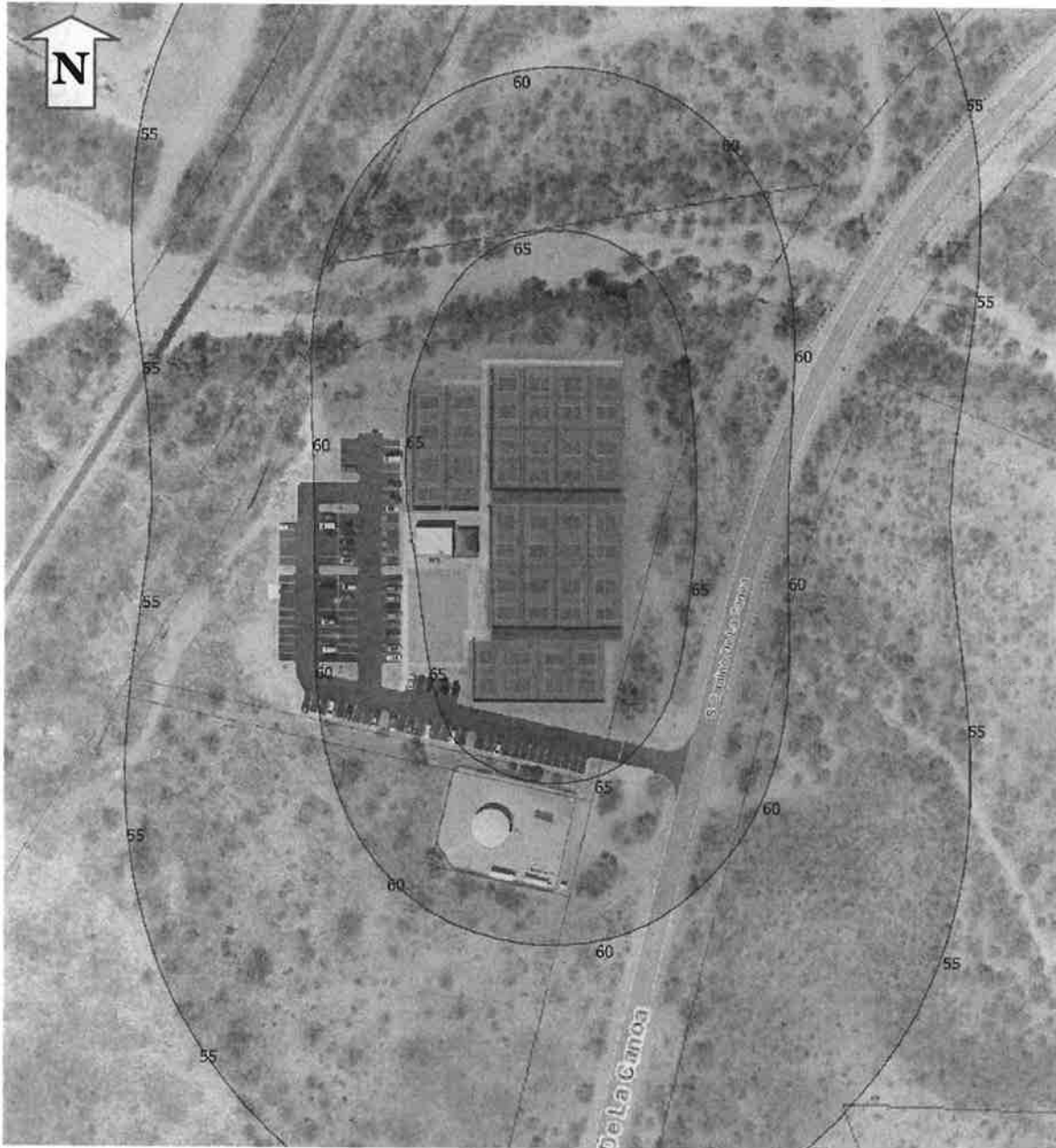
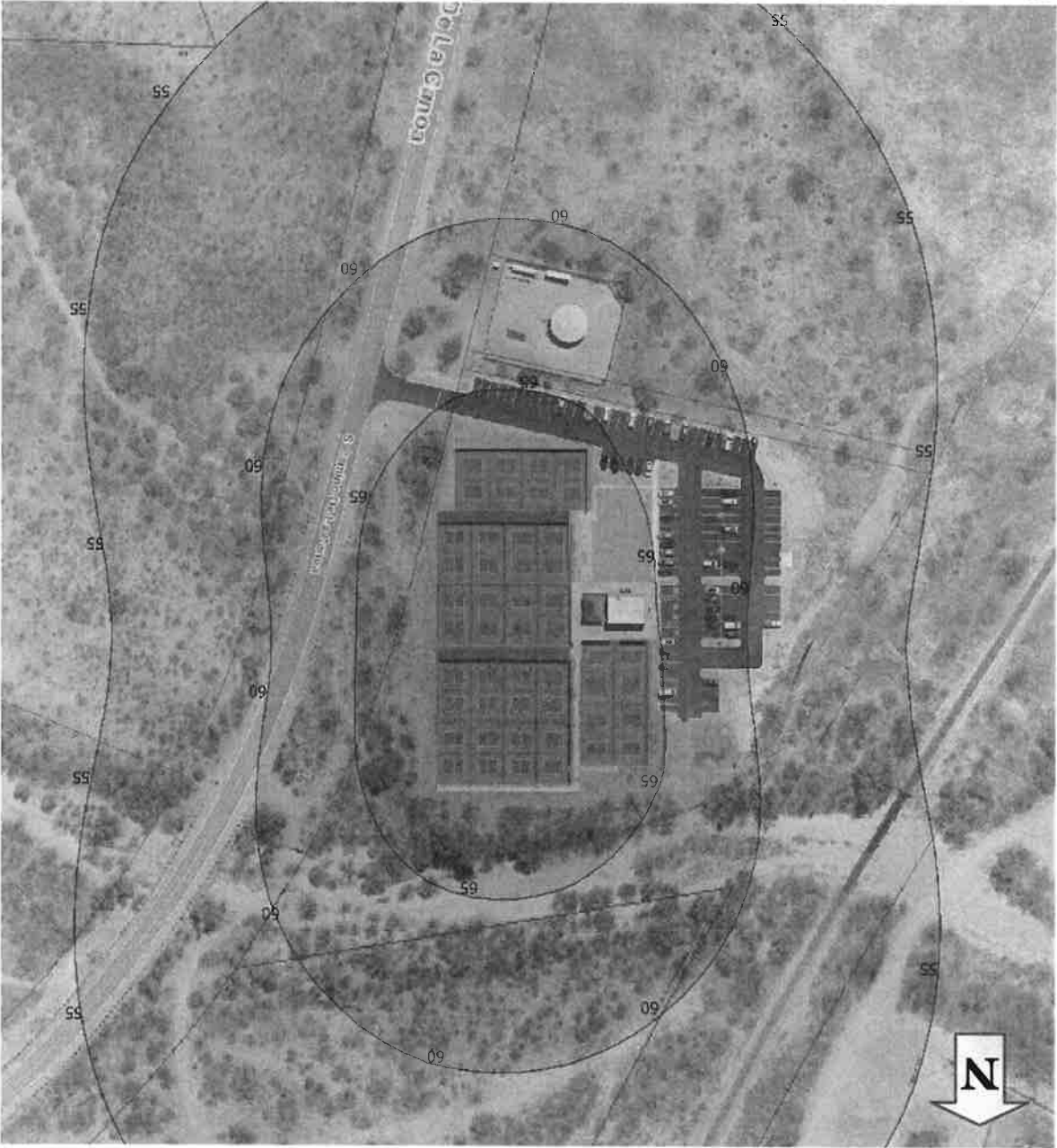

Figure 7.2. Adjusted Sound Pressure Level from Eight Pickleball Courts Aligned Longitudinally

Figure 7.3. Adjusted Sound Pressure Level from Eight Pickleball Courts Aligned Laterally



7.2 Topography

7.2.1 Sight Lines

In order for a noise barrier to be effective, it must block the line of sight from the sound source to the point of observation. Homes sitting at an elevation higher than the proposed pickleball courts can be difficult to shield, particularly if they have more than one floor, balconies, or raised decks. Attention must be given to sight lines to determine whether a sound wall system can be a practical solution as a noise abatement treatment.

7.2.2 Noise Sensitive Locations Above Ground Level

In addition to elevation differences between the pickleball courts and surrounding properties, multistory housing can also result in sight line issues that lead to poor shielding. Figure 7.4 shows a mitigation example with four active pickleball courts in the southwest corner of the complex and a two story building to the south. A 10 foot sound wall (red line) has been placed along the south and west sides of the courts. The sound pressure level contours are at an elevation of 5 feet above grade. The 55 dBA contour does not reach the building.

In Figure 7.5, the elevation of the sound pressure level contours has been raised to 15 feet above grade, about the height of a second floor bedroom window or a person standing on a second floor balcony or raised deck. The 55 dBA contour can now be seen to contact the building. This shows the importance of checking all floors of nearby structures to ensure that acoustical design targets are being met.

It is important to note that, since the observation point on the second floor can overlook the sound wall, some paddle impacts will not be shielded. Although the partial shielding of the majority of the sound source locations is enough to lower the adjusted sound pressure level close to the target level of 55 dBA, peak sound pressures may not decrease as much as the adjusted level since some individual paddle impacts will not be shielded and may still have a significant noise impact.

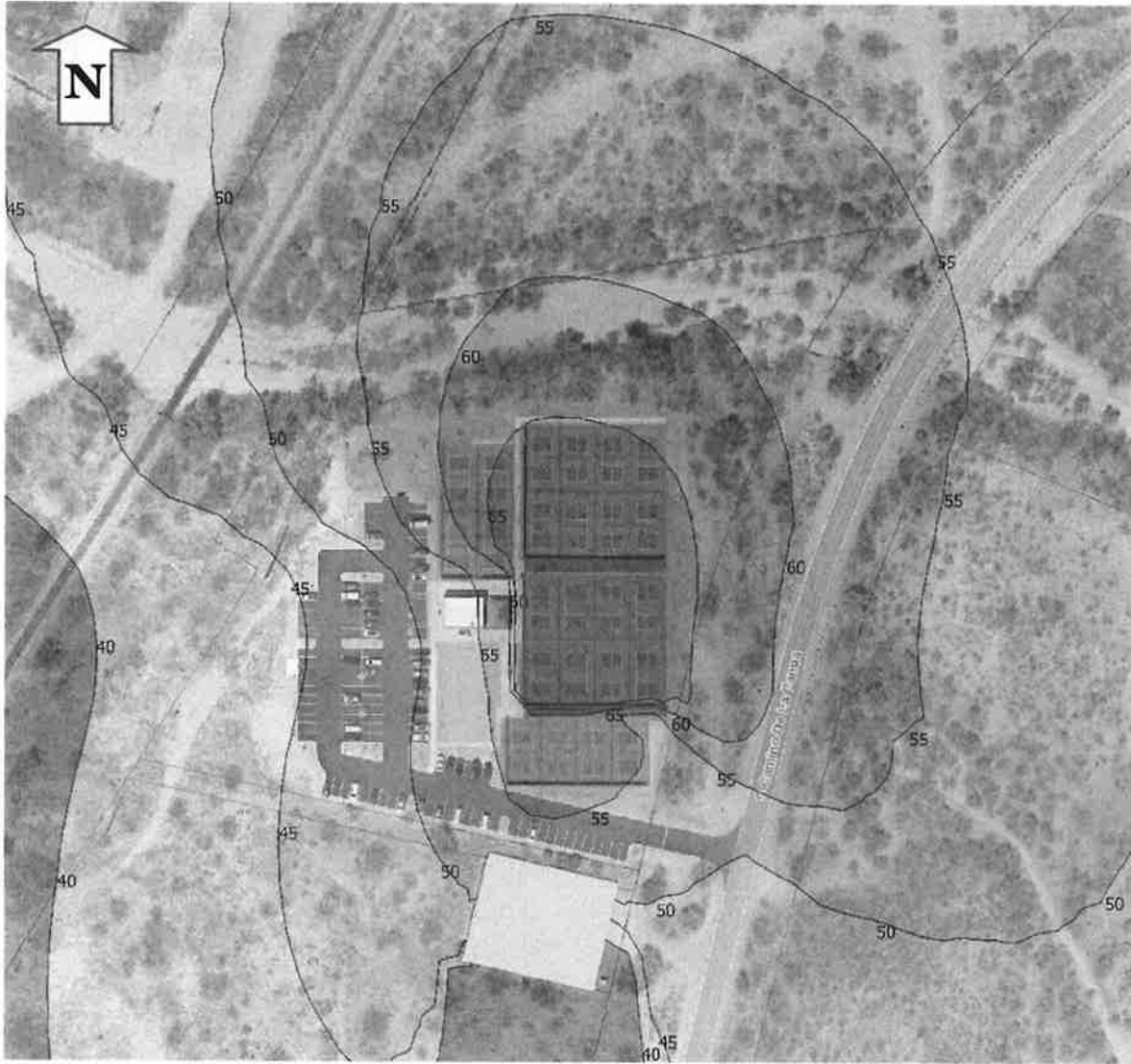

Figure 7.4. Adjusted Sound Pressure Level Contours, Four Courts, 10 Foot Wall, 5 Foot Elevation

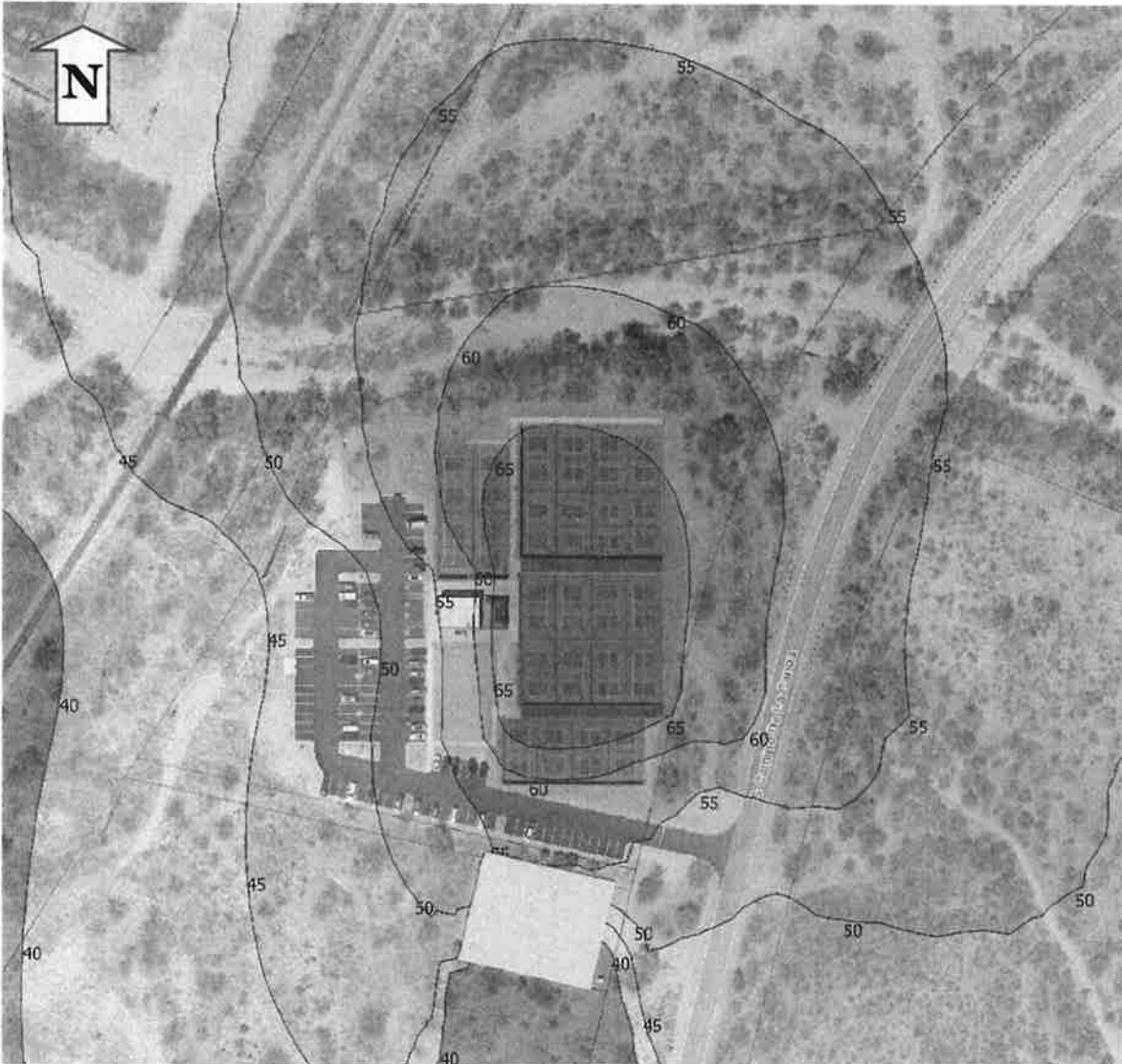

Figure 7.5. Adjusted Sound Pressure Level Contours, Four Courts, 10 Foot Wall, 15 Foot Elevation

7.3 Ground

7.3.1 Attenuation

Some amount of attenuation can occur for sound passing over porous ground. This will mostly include friable soil with vegetation growing on it. Hard surfaces like concrete and asphalt are reflective. Painted concrete surfaces like sports courts are very reflective.

This should be considered when placing a noise barrier on a particular ground type. The barrier will block the ground wave and remove the ground effect. This will affect the performance of the noise barrier. Blocking the ground wave over hard ground will enhance the insertion loss, the difference in before and after sound levels, of the barrier while blocking the ground wave over absorbing ground may cause the insertion loss of the barrier to be less than expected.

7.3.2 Refraction

Refraction caused by temperature gradients over certain ground can effectively cause sound to travel farther. Refraction is the bending of the path sound travels towards regions of lower sound speed, e.g. cooler air. This can be the result of temperature stratification of the atmosphere or wind. In low lying places where cool air tends to collect in the evenings or over irrigated ground where evaporative cooling can occur such as a golf course, a temperature lapse condition can develop with warm air above and cool air below. This will result in sound arcing down toward the ground. Refraction caused by a temperature lapse condition can result in sound arcing over obstacles on the ground that would normally impede its propagation thereby making it louder at farther distances.

7.3.3 Valleys

Parks located at the bottom of a valley can pose a particular challenge as they tend to experience temperature stratification conditions regularly. Further, the sides of the valley may trap sound and send it echoing back to locations on the opposite side. Valleys often require a detailed propagation study to understand how sound moves through the area at different times of the day.

7.3.4 Water

Bodies of water such as a pond or lake are a special type of ground that is highly reflective. It also tends to form a layer of cool air near its surface causing refraction effects similar to those described above. Sound propagation over water can be difficult to predict as its surface changes with wind and weather conditions. In calm conditions sound carries long distances over the surface of water. If a significant portion of the ground between a sound source and receiving property is water a detailed propagation study may be needed to determine the ground attenuation.

7.4 Reflective Surfaces

Surfaces that reflect sound that are close to the pickleball courts can redirect sound in undesirable directions. These surfaces can be building facades, retaining walls, or even noise barriers. Mass-loaded vinyl (MLV) fence covers are particularly reflective and may not be appropriate in some applications. Unpainted masonry walls retain some porosity and will absorb a small amount of sound, but should be considered reflective for the purposes of outdoor sound propagation.

Reflected sound from a single surface may increase the total sound pressure level as much as 3 dB over the level of the sound coming directly from the source. (Due to the short duration of the impulse produced by a paddle impact and its short wavelength it is difficult to get the reflected

sound to sum coherently with the direct sound) The positions of noise barriers must be planned strategically to prevent sound from going in unwanted directions and creating a new noise issue.

Parallel reflective surfaces can severely degrade the performance of a noise barrier. See Section 9.2.3 for more information on this design issue.

8. Noise Assessment Procedures for Pickleball Sound

8.1 Inaccuracies of Simple Averaging Techniques

8.1.1 Equivalent-continuous Sound Pressure Level

The equivalent-continuous level (L_{eq}) is a type of average sound pressure level over the entire period of a measurement. It represents a sound pressure level that has the same total energy as a measured sound pressure level that may vary over the time of the measurement.

While the equivalent-continuous sound pressure level includes all acoustical events and background noise that occur during the time of a measurement, including short impulsive events such as pickleball paddle impacts, it only gives an indication of the average level. It is not strongly influenced by peak sound pressure levels. For example, four pickleball courts may produce 50 to 60 paddle impacts each minute. That is one impact about every second. Equivalent-continuous averaging will therefore spread the energy of each paddle impact over a period of about one second. The result is that the paddle impacts will usually be indistinguishable from the background noise due to their very short duration. This, however, will not be what is reported by observers near the courts.

The main issue with using equivalent-continuous sound pressure level with pickleball is that it cannot be used to assess impulsive sound. This is the primary concern of neighbors living close to pickleball courts. A different metric that can account for the noise impact of the paddle impacts must be found.

8.1.2 Exponential Time Weighting

Sound level meters will typically have two smoothing filters called fast and slow time weighting having time constants of 0.125 and 1.0 second respectively. These are first order lowpass filters applied to the square of the sound pressure and are known as exponential time weighting. Some meters will also have an impulse peak hold filter with a 35 millisecond time constant on the rise of the sound pressure level and a slow 1.5 second decay to assist in reading the maximum level.

Fast exponential time weighting is often recommended for assessing impulsive sound. For highly impulsive sounds having short durations this metric does not work well. When the averaging time of the time weighting is longer than the duration of the impulse, the impulse is in the stopband of the lowpass filter. In other words, the time weighting is filtering out the impulsive sound source being measured. That is the purpose of a smoothing filter.

Figure 8.1 demonstrates the filter response to a burst of sound just long enough to achieve a reasonably accurate reading within 0.5 dB of the true sound pressure level. The red curve represents the envelop of a burst of sound 0.277 seconds in duration. This is the time required for

the output of the fast exponential time averaging filter (blue curve) to rise to within 0.5 dB of the actual sound pressure level of the sound burst. When the sound burst ends, the output of the exponential time averaging filter begins to decay. The peak value in the output of the fast exponential time averaging filter, after being converted to sound pressure level, is known as the L_{max} level.

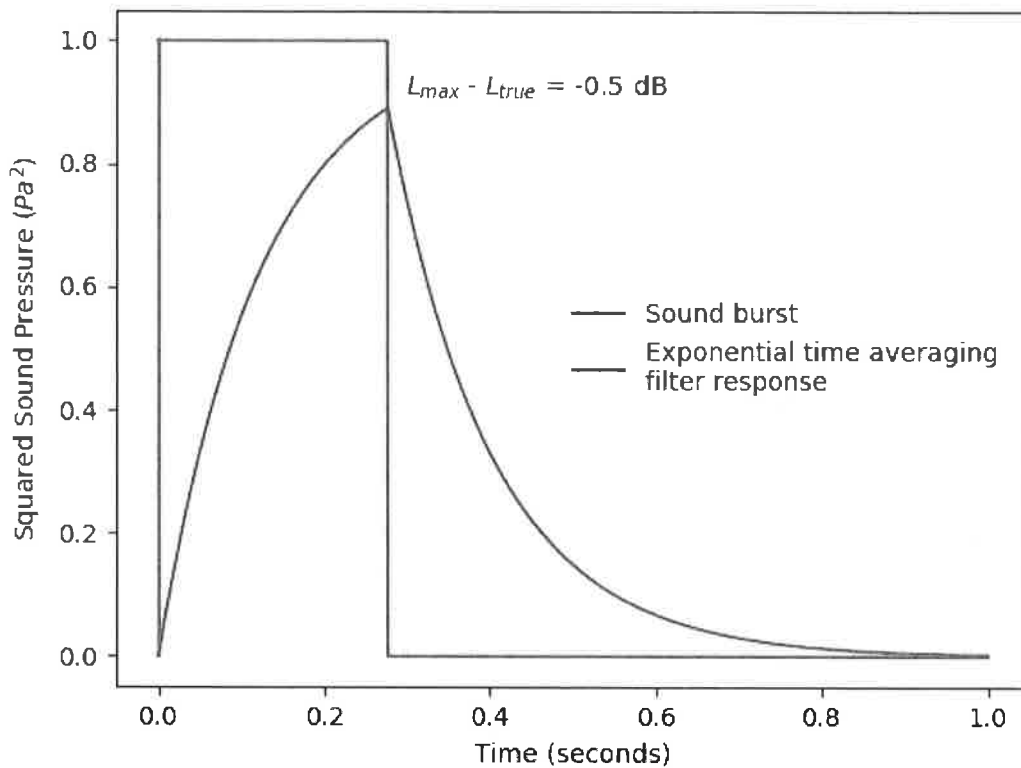

Figure 8.1. Fast Time Averaging Filter Response to a 0.277 Second Sound Burst

Figure 8.1 shows the behavior of the fast exponential time averaging filter and L_{max} when used properly. Figure 8.2 illustrates how the fast exponential time averaging filter responds to a typical pickleball paddle impact. Note that the time scale has been reduced for clarity. At the end of the 0.002 second impulse, the fast exponential time averaging filter has only had time to rise to a level that is 18 dB below the true sound pressure level of the impulse. The pickleball paddle impulse is so much shorter than the time constant of the averaging filter that the exponential

curvature of the filter response is not even visible. It is clear that fast exponential time weighting, much less slow exponential time weighting, cannot be used to assess the noise impact of pickleball paddle impacts.

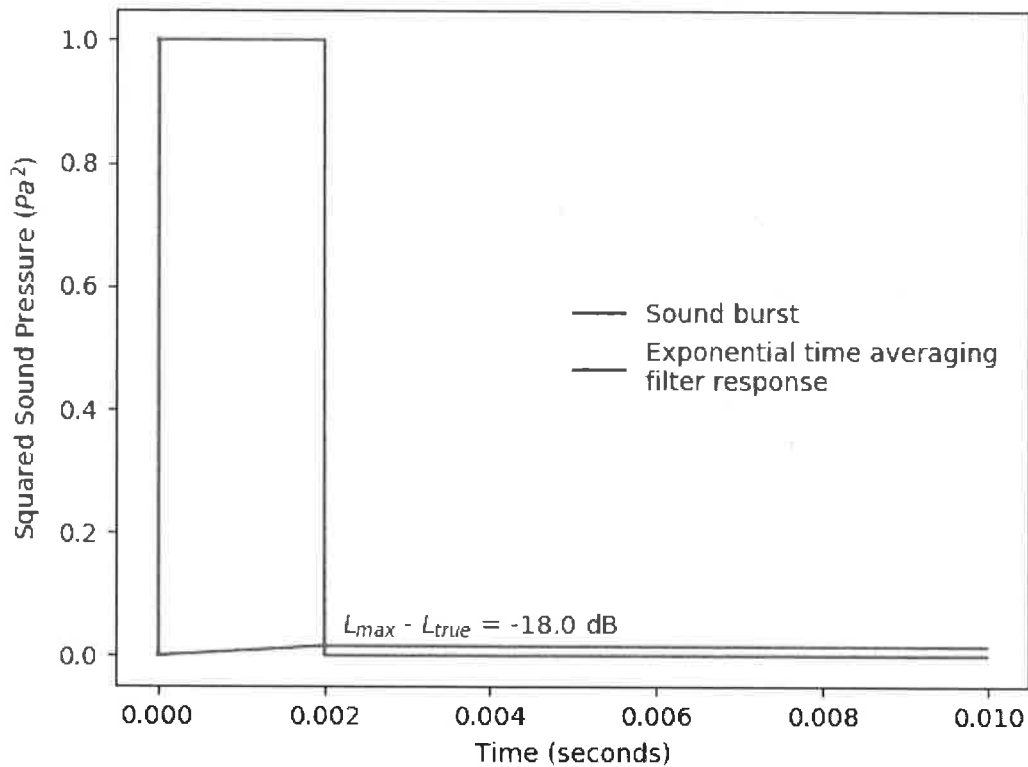

Figure 8.2. Fast Time Averaging Filter Response to a Typical Pickleball Paddle Impact

8.1.3 Percentile Sound Pressure Levels

Another common method of analyzing sound pressure level over time is to rank the levels by the percentage of time that a given level is exceeded. Percentile sound pressure level is described in Section 5.1.5. For impulsive sound, percentile levels suffer from the issues of both equivalent-continuous and exponential time weighted levels.

The majority of the energy in pickleball paddle impacts constitutes a very small percentage of the total measurement time. Even very low percentile levels like LA_{01} , the sound pressure level

exceeded 1% of the time, are little influenced. Further, percentile levels are usually calculated from the fast exponential time weighted level, a metric that already strongly attenuates the short duration impulses of the paddle impacts. Like the previous averaging methods, percentile sound pressure levels do not distinguish paddle impacts well from background noise and correlate poorly with the community response to this type of sound source.

8.2 Best Practices for Assessment of Impulsive Sound

Assessment of impulsive sound is multi-dimensional. In addition to loudness, other characteristics like onset rate, duration, and frequency range need to be considered as well to gauge the true noise impact. Due to the short duration of paddle impacts, averaging sound pressure level metrics such as equivalent-continuous level (LAeq), maximum fast exponential time weighted level (LMax), and impulse time weighting (LAI) fail to accurately represent the perceived loudness and annoyance of the paddle impacts and impact processes in general. To get a better correlation with the actual response of the surrounding community to this type of sound metrics with a shorter time scale are needed.

The paddle impact sound pressure level is better represented by a combination of peak sound pressure level and sound exposure level (SEL). Using the sound exposure level involves windowing the measured sound pressure in time to include only the paddle impact and reflections from nearby surfaces as seen in Figure 6.1. The equivalent-continuous sound pressure level of the windowed impact is then normalized to the length of the window giving a representation of the energy in the impact alone. Appropriate adjustments for impulsive sounds can then be applied to the impacts as described next.

Most acoustical standards for sound pressure levels with regard to compatible land use provide adjustment factors for different types of sound, e.g. impulsive, tonal, time of day, etc. Each of these categories of sound produces different levels of community impact and annoyance due to their temporal or spectral characteristics in comparison to a broadband sound that does not vary in level or frequency content with time. The purpose of the adjustment factors is to normalize these types of sound to a neutral broadband sound pressure level so that they can be reasonably compared to a defined sound pressure level limit.

ANSI S12.9 Part 4 and ISO 1996 Part 1 give criteria for assigning adjustment factors to a variety of sound classifications. Sounds produced by impact processes are typically classified as 'highly impulsive' due to their high onset rates and intrusiveness and assigned a 12 dB adjustment. Experience has shown that pickleball paddle impacts should be adjusted as highly impulsive sounds in order to set appropriate performance goals for abatement treatments. Inadequate abatement treatment may lead to ongoing complaints, strained relations with neighbors, legal action, the need for continued involvement on the part of authorities, retrofitting, and possibly demolition costs to improve the abatement later.

8.3 Measurement Procedures for Highly Impulsive Sound

8.3.1 Measuring the Paddle Impacts

General procedures for conducting and reporting acoustical measurements have been covered in Chapter 5. For pickleball, the sound level meter should be set up to record continuous audio. This will be needed for assessing the impulses produced by the paddle impacts. The audio should be written to an uncompressed file format such as WAV with the following properties.

- Encoding: linear PCM WAV file format or other suitable lossless audio file format
- Sampling rate: 48 kHz (minimum)
- Resolution: 24 bit (minimum)

Audio recordings of the field calibration tone should be made as well and the Leq noted for future reference.

Logged data should be sampled at no more than one second intervals and include for each log interval,

- Peak sound pressure levels
 - LApk (A-weighted peak level)
 - LZpk (unweighted peak level)
- For speech assessment
 - LAmax (maximum A-weighted fast exponential time weighted level)
- For background level
 - LAeq (A-weighted equivalent-continuous level)
 - LAF (A-weighted fast exponential time weighted level)
 - LAS (A-weighted slow exponential time weighted level)

8.3.2 Measuring Background Levels

Background noise level measurements should be made without pickleball activity at each measurement location. In practice it has been found that background levels should be performed either before or after the pickleball courts are in use so as not to disrupt the rhythm of play by starting and stopping or otherwise interfering with the use of the courts. For noise monitoring situations where the sound level meter is left to run all day it may be necessary to find a time in the recorded data where the pickleball courts were not being used in order to assess the background noise level at different times of day.

8.3.3 Data Analysis

Analysis of the measured data is performed on the sound exposure levels of the individual, A-weighted paddle impacts. A minimum of 30 paddle impacts should be obtained at each test location.

Sound Exposure Level

Some analysis and reporting software packages that work with a particular sound level meter may be able to do sound exposure analysis; however, they must be able to work on time scales less than one second. While the main part of the acoustical energy occurs within about a 10 millisecond window, later reflection and reverberation must also be included in the sound exposure window. The sound exposure should include all of the initial impulse and reverberant decay tail. See Sections 5.1.6 and 5.5.3 for more information on calculating sound exposure level.

Background Noise Correction

A background correction should be applied to each paddle impact. Since these are short impulses, only a small sample of the background noise immediately before, or if necessary after, the paddle impact is needed. This will give a more accurate correction in areas of high activity where the background noise level is fluctuating between paddle impacts. The procedure for background noise correction is explained in Section 5.3.2. It should be carried out on the equivalent-continuous level of the individual paddle impact, not on the sound exposure level directly. The background corrected equivalent-continuous level of the paddle impact is then converted to a sound exposure level for further analysis.

Adjusted Sound Pressure Level

There are two adjustments that will normally apply to pickleball paddle impacts, highly impulsive and day of week. The highly impulsive adjustment is 12 dB.

Noise assessment should be performed for the most impactful use case. A 5 dB adjust is therefore applied to account for the additional noise sensitivity during times when neighbors tend to be at home such as weekends and evenings.

This brings the total adjustment to 17 dB. The adjustment can be applied directly to the calculated sound exposure levels.

Now that the sound exposure levels have been adjusted, the adjusted sound pressure level can be calculated. This procedure is explained in Section 5.5.3. The adjusted sound pressure level can now be compared to applicable maximum permitted sound levels.

8.4 Noise Assessment of Spectator Speech

For larger crowds of people such as found at a tournament, ANSI S3.5 provides standard speech power levels for different vocal efforts. The loud vocal effort may be most appropriate for most events.

Sound pressure level measurements of spectators at a tournament would be a better estimate where possible. Differences in the number of spectators present during the measurement and the number expected at the proposed venue should be taken into account.

8.5 Site Simulation

An ISO 9613 or other suitable outdoor sound propagation standard can be used to calculate sound pressure levels at neighboring properties. Other more detailed environmental noise simulation methods exist and are also acceptable; however, ISO 9613 is simple and widely used with reasonable accuracy in most situations. There are many software packages available that implement this standard propagation model such as SoundPlan and iNoise.

8.5.1 Modeling Distributed Sound Sources

Figure 8.3 shows the dimensions of a pickleball court. Most paddle impacts occur between the baseline and no volley zone on each half of the court; however, serves are required to be made from behind the baseline.

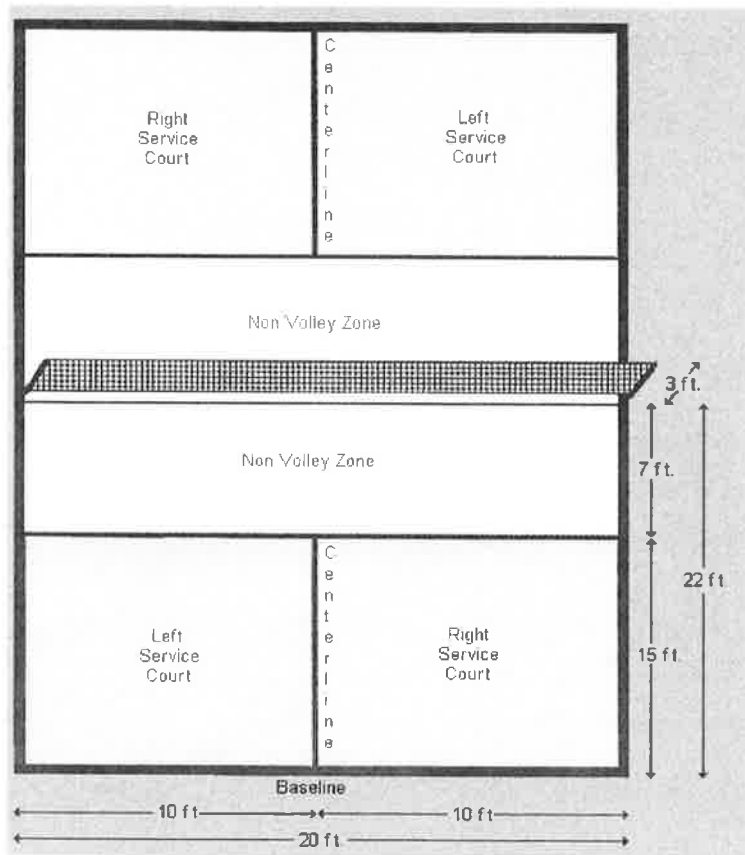

Figure 8.3. Pickleball Court Dimensions

Sound radiated from pickleball courts will not follow the inverse square law until the distance to the point of observation is large compared to the dimensions of the court or group of courts. The inverse square law states that sound radiated from a point source will decrease in level at a rate of 6 dB for every doubling in distance. As seen in Figure 8.4, this does not hold true for distributions of sound sources at close range. The figure compares two sound sources at the opposite baselines of a pickleball court to a single source approximation located at the center of the court. The vertical dashed green lines represent the edges of the concrete pad. The lower graph is the difference between the two curves in the graph above. The point of observation must be almost three court lengths before the level difference is within 0.5 dB.

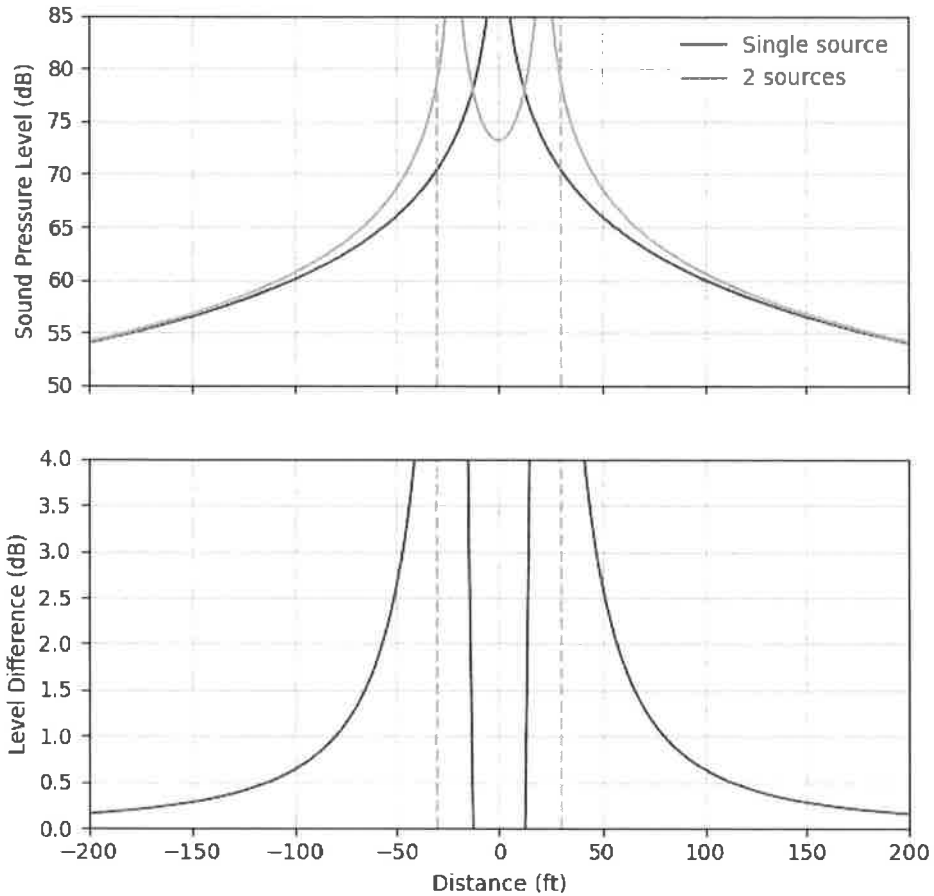

Figure 8.4. Sound Pressure Level at Distance from Court Center for One and Two Sources

For this reason, it is recommended to use multiple sound sources on each pickleball court when constructing an acoustical model of the courts. A vertical area source, i.e. a distribution of sound sources on a vertical plane located at the baseline at each end of each court extending the width of the baseline and from the playing surface to a height of 8 feet, is recommended. This arrangement is chosen for simplicity and to better ensure that the extents of noise barriers are not underestimated in the noise abatement planning stage.

8.5.2 Pickleball Court Directivity

As described in Section 6.4, pickleball courts have a directivity pattern that is bidirectional. Measurements at numerous pickleball courts have shown that the directivity pattern can be

approximated as shown in Table 8.1 or by using Eq. 8.1 where θ is the angle of the receiver with respect to the direction of play and D is the attenuation in decibels from the directivity.

$$D = 20 \log_{10}(\sqrt{(\cos^2(\theta) + 10^{(-5.5/10)} \sin^2(\theta))}) \quad (8.1)$$

Angle (deg)	Attenuation (dB)
0	0.0
10	-0.1
20	-0.4
30	-0.8
40	-1.4
50	-2.2
60	-3.1
70	-4.0
80	-4.7
90	-5.0
100	-4.7
110	-4.0
120	-3.1
130	-2.2
140	-1.4
150	-0.8
160	-0.4
170	-0.1
180	0.0

Table 8.1. Pickleball Court Directivity Pattern

9. Noise Abatement Methods

When a noise impact assessment indicates that activities planned for a site exceed the limits set in the noise regulations, a noise abatement plan to bring the site into compliance should be prepared by a qualified acoustical engineer.

9.1 Setbacks

A noise abatement plan begins with sufficient setback to noise sensitive areas to make abatement treatments effective. Any given noise abatement treatment will produce a limited amount insert loss or attenuation. A noise abatement plan for a site generally consists of a number of different treatments that work together to achieve an acceptable sound level in the surrounding area. Any deficit in the amount noise reduction achievable through mitigation treatments must be made up for in setback. In short, the setback is what makes the rest of the noise abatement plan possible.

One approach to setbacks is to simply prescribe a minimum setback with regard to all residential land uses. This has been done recently by Park City, Utah. Under their new pickleball code amendment [Park City], proposed pickleball courts within 600 feet of residential properties must have a noise abatement plan prepared. Pickleball courts within 150 feet of residential properties are not permitted.

This approach has the advantage of being easy to understand and apply; however, there are some situations where it may not be possible to create an effective noise abatement plan at 150 feet due to elevation differences or multi-story housing that make sufficient shielding by a sound wall impractical or impossible. In some special cases it may be possible to mitigate pickleball courts closer than 150 feet. Thus a 150 foot setback requirement would be overly restrictive in these applications.

Pickleball courts within 100 feet of residential land uses have proven to be problematic resulting in lawsuits, strict limitations on usage, and court closures. Courts within 150 feet of residential land uses require careful noise abatement planning using modern methods of noise assessment for highly impulsive sound such as ANSI S12.9 Part 4 described in previous chapters and strict adherence to design specifications.

9.2 Noise Barriers

9.2.1 Performance Requirements

Sound walls and fence covers are the main noise abatement treatments utilized for pickleball noise control. Sound walls are a more permanent and aesthetic solution while fence covers have lower material and installation costs. Both types of barriers can have reflective or sound absorbing surfaces.

There are a variety of materials and products available that are acceptable for pickleball mitigation. It is important that they meet a few minimum requirements.

Sound must not be able to penetrate through the barrier material. For pickleball, this means the barrier material must have a minimum sound transmission class (STC) of 20. This is not difficult to achieve with many solid materials that can include many options from mass-loaded vinyl (MLV) fence covers to masonry walls. Materials such as wind screens attached to court fencing and vegetation in the form of a hedges provide a level of visual privacy, but should not be considered noise abatement treatments.

In order to maintain the integrity of the barrier transmission loss, penetrations in the barrier surfaces cannot exceed 1% of the surface area. There can be no gaps between the bottom of the barrier and the ground or between barrier sections. Fence covers must be installed with the manufacturer's recommended amount of panel overlap.

9.2.2 Fence Cover Safety Notice

IMPORTANT

Standard chain link court fencing may not be rated for wind loading with a solid material attached. This can pose a danger of fence collapse in high winds. Many fence manufacturers produce reinforcement kits to stabilize fencing for this type of loading. It is important to consult with the fence manufacturer or a structural engineer prior to attaching MLV, sound blankets, or anything other solid material to an existing open link fence.

9.2.3 Parallel Surfaces

A common problem encountered when designing a noise barrier system for pickleball courts is the need to shield homes on opposite sides of the courts. Arranging reflective noise barriers so that they have parallel faces creates a situation where the sound is trapped between the interior surfaces and cannot dissipate. It has nowhere to go but over the noise barrier. This will significantly degrade its acoustical performance. If this layout cannot be avoided by changing the relative positions of the two walls, sound absorption will be needed on the interior surfaces to control acoustical energy buildup.

Figure 9.1 shows a performance comparison of several surface materials on opposite sides of two pickleball courts arranged end to end. Carsonite is a sound wall system with integrated sound absorption. It is commonly used for noise mitigation along roadways and absorbs well at 1,000 Hz, the critical frequency for pickleball paddle impacts. AudioSeal is an outdoor sound absorbing blanket material that can be attached to a fence. It does not absorb as well as the Carsonite at higher frequencies, but still performs adequately. The MLV curve is notably higher than the AudioSeal and Carsonite curves due to its high reflectivity at 1,000 Hz.

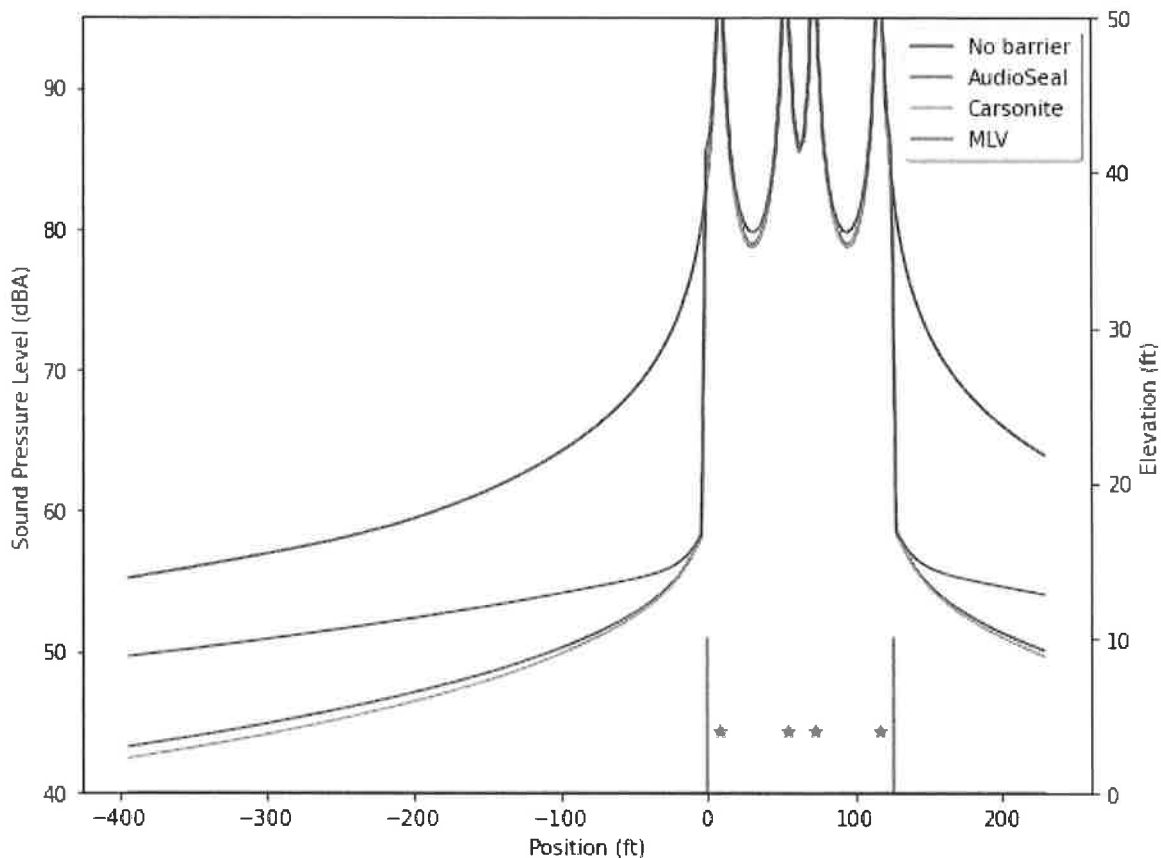

Figure 9.1. Performance Comparison of Interior Parallel Surfaces of Noise Barriers

It should also be noted that the slopes of the AudioSeal and Carsonite curves are almost identical to the slope of the curve for no noise barrier. The MLV curve has a notably shallower slope that trends toward the no barrier use case at distances farther from the noise barrier. This is the result of the large number of high amplitude image sources produced by reflective interior surfaces of the MLV.

Note: The ISO 9613 standard contains provisions for only one reflection. Acoustical simulation software implementing this standard will not calculate the case of parallel walls accurately. The above figure was created using multiple image sources and 40th order reflections for the MLV surfaces in order to get convergence on a solution.

9.2.4 Lowering Pickleball Courts

One approach to free standing sound walls is to lower the elevation of the pickleball courts by excavating the soil at the location of the courts and using it to create a berm next to the courts. While this can have some acoustical benefits in some situations, it is more of a cost saving design choice. By constructing the sound wall on top of the berm, a lower wall height will be

required and the wall will be less expensive to build.

9.2.5 Ventilation and Air Flow

In summer, pickleball courts, like any outdoor sport played on a hard court, can become hot. Sound walls and fence covers will impede the air flow over the courts and make the courts feel even warmer. It may be possible to alleviate this to a degree by using overlapping wall sections that allow some breeze to pass through. This usually requires an overlap of at least four times the width of the gap between the wall sections. Sound absorbing material may also be needed in the gap to control flutter reflections that allow sound from the pickleball courts to work its way through the overlap. There must be no line of sight to players on the courts possible through the gap. If necessary, add a wall extension to shield the outside opening of the overlap. This wall layout can also be used as a passageway for ingress and egress.



Figure 9.2. Sound Wall Overlap

9.3 Court Orientation

From the examples of pickleball court directivity in Section 7.1, it is apparent that the orientation of pickleball courts can be used as a noise mitigation measure. By turning the courts so that a noise sensitive area is to the side of the courts, sound levels in that direction can be reduced 3 to 5 dBA.

This may not be an ideal solution in some situations. It is preferable to have the direction of play roughly north-south to reduce glare from the sun during play. It is, however, worth the effort to take advantage of this characteristic of pickleball paddle radiation when it will not interfere with the use of the courts.

9.4 Sound Masking

9.4.1 Masking Requirements

Masking of a sound source refers to changing the threshold of hearing by introducing another

sound source such that the first sound source can no longer be heard. This is difficult to achieve with impulsive sounds because of their high peak sound pressure levels. Since impulsive sound is by nature intermittent and of limited duration, a masking source would have to operate continuously at a high amplitude in order to mask the impulse. This will often create a new noise issue.

Pickleball paddle impacts produce sound mostly in the 1,000 Hz octave band. The masking source must therefore also produce sufficient sound in the 1,000 Hz octave band to cover the sound of the paddle impacts.

9.4.2 Roadways

Roadways are a broadband, continuous sound source. In general, even busy highways are not able to mask pickleball courts due to the high peak sound pressures of the paddle impacts. Traffic noise tends to be mostly low to mid frequency sound and does not have sufficient energy in the 1,000 Hz octave band to effectively mask pickleball.

It appears to be a common perception that placing pickleball courts in neighborhoods located close to main arteries or interstates will prevent noise issues due to the sound from the roadway. In practice, this has not proven to be the case as seen at Glenhaven Park in La Cañada Flintridge, California [La Cañada Flintridge]. This neighborhood park is located adjacent to Interstate 210 on the north side of Los Angeles.

9.4.3 Fountains

There is some evidence that water fountains can be beneficial under certain conditions. As discussed above, a masking source must produce sufficient sound in the 1,000 Hz octave band and operate at all times in order to mask pickleball. Water falling on water can produce significant sound in the 1,000 Hz octave band.

Fountains located close to a noise sensitive area such as a back patio that is several hundred feet from pickleball courts may produce partial masking of paddle impacts from the courts. It may be possible to reduce this distance with a sound wall system at the pickleball courts.

For noise sensitive areas close to pickleball courts this is not likely to be an effective noise abatement treatment. Larger noise sensitive areas or larger numbers of homes will require multiple fountains in order to keep the distance from the fountains to the individual homes relatively small compared to the distance to the pickleball courts.

9.5 Full Enclosure of Pickleball Courts

For outdoor pickleball courts that cannot be mitigated because of insufficient available setback, topography, elevation features of the surrounding structures, or some other reason, the only remaining noise abatement option may be a full enclosure to contain the sound. Any penetrations in the building shell will need to be analyzed for sound leakage including doors, windows, ventilation, exhaust fans, etc. Vestibule doors may be necessary in some applications where ingress and egress face noise sensitive areas.

Indoor courts with bay doors opening away from noise sensitive areas can also work in some instances. In this use case, a room analysis of the reverberant field will need to be done and the amount of sound power exiting through the bay doors calculated from the direct and reverberant sound fields. Buildings can be much higher than free standing wall and provide a better performing noise barrier.

9.6 Noise Control Policy

9.6.1 Hours of Operation

Limiting the hours of operation of the pickleball courts to certain times of the day or days of the week can sometimes be an effective noise control strategy. These arrangements are often negotiated with neighbors.

9.6.2 Restrict Players Allowed to Use Courts

In some cases, restricting court usage to, for example, club members and their accompanied guests can increase accountability for how the courts are used. While this may also reduce the amount of players that use the courts, noise abatement planning should assume the courts will be used at full capacity.

9.6.3 Speech

A pickleball court properly mitigated for paddle impacts will generally not have noise issues related to the loudness of speech on the courts. Noise issues with speech are for the most part related to content rather than sound level. If this is the case, a prohibit on swearing and other offensive speech may be necessary.

9.6.4 Restrictions on Equipment

Quieter Equipment

In practice, the enforcement of the use of specific types of pickleball equipment, paddles and balls, has proven to be difficult to manage for home owners associations, country clubs, parks, and most other types of pickleball facility. In order for this to be considered a noise abatement measure, there must be a clear policy in place and personnel dedicated to monitoring activity on the courts to ensure unsanctioned equipment is not in use.

Paddles

There has been an effort in the pickleball paddle industry to move to quieter designs and most players are already using this “green list” equipment as it is referred to. Measurements by Spendiarian & Willis at a number of pickleball facilities have found that the mean sound exposure level of paddle impacts, when normalized to distance and ground type, is very consistent. This indicates that, in aggregate, most players are either using essentially the same equipment or that there is not a significant acoustical difference in the equipment used. During

testing where the make and model of the paddles in use have been recorded, it has been found that most players were using green list paddles. At the present time green list paddles should not be considered a noise control measure since most players are already using this equipment anyway.

Foam Balls

Measurements by Spendiarian & Willis comparing foam pickleballs to common regulation balls has shown that the foam balls can be 8 to 9 dB quieter than regulation balls. While the use of foam balls is an effective noise abatement measure, it is undesirable for pickleball players as the foam balls play very differently from the regulation balls and cannot be used in tournaments or to train for them.

10. Site Planning Considerations for Pickleball

10.1 When a Noise Impact Assessment Is Needed

Courts located within 350 feet of residential properties in most cases require noise abatement. Pickleball court sites within 500 to 600 feet of noise sensitive areas should be reviewed by a qualified acoustical engineer in the site selection phase of the project. In the case that the ground between the pickleball courts and receiving property is water this distance may extend 800 to 1,000 feet in some cases. Courts located within 150 feet of homes require careful and often extensive noise abatement design to avoid complaints. Placing open air pickleball courts within 100 feet of residential properties is not recommended.

10.2 Site Selection

10.2.1 Available Setbacks

The most important factor to consider in selecting a site for pickleball courts is the distance to adjacent residential land uses. While a noise barrier such as a sound wall or mass-loaded vinyl fence cover can be effective in reducing noise impact, it can only provide a limited amount of insertion loss, usually between 8 and 12 dB depending on the ground it is installed on, flanking paths, reflecting surfaces, and other factors. The rest of the noise reduction required to meet acceptable sound levels must mostly be gained through distance. It is important to ensure that there is enough buffer so that noise abatement installed can be adequately effective. Other site conditions that may increase the setback required are discussed in the following subsections.

10.2.2 Proximity to Multi-story Residential Structures

In order for a noise barrier to be effective it must be able to block the line of sight from the sound source to the receiving land use. Pickleball paddle impacts can occur from near the elevation of the playing surface to a height of about 8 feet above it. Multi-story housing located close to the proposed pickleball courts may not be adequately shielded a wall system. This can affect upper level windows, balconies, raised decks, other amenities located above ground level. These need to be included in the noise impact assessment of the proposed pickleball courts.

10.2.3 Topography

Similar to housing with floors above ground level, homes sitting at an elevation higher than the proposed pickleball courts can also be difficult to shield with a noise barrier.

In addition, refraction caused by temperature gradients over certain ground can effectively cause sound to travel farther. Refraction is the bending of the path sound travels towards regions of

lower sound speed, e.g cooler air. This can be the result of temperature stratification of the atmosphere or wind. In low lying places where cool air tends to collect in the evenings or over irrigated ground where evaporative cooling can occur such as a golf course, a temperature lapse condition can develop with warm air above and cool air below. This will result in sound arcing down toward the ground. Refraction caused by a temperature lapse condition can result in sound arcing over obstacles on the ground that would normally impede its propagation thereby making it louder at farther distances.

Parks located at the bottom of a valley can pose a particular challenge as they tend to experience these conditions regularly. Further, the sides of the valley may trap sound and send it echoing back to locations on the opposite side. Valleys often require a detailed propagation study to understand how sound moves through the area at different times of the day.

10.3 Tournaments

The main difference in sound from pickleball courts during tournaments will be spectators. The noise assessment and abatement planning should include a speech analysis based on the number and location of spectators. This has been described in Section 8.4.

If a PA system is to be used for announcements, limits on the system gain should be established to ensure sound levels reaching the surrounding properties remain acceptable. Noise monitoring may also be employed at the property boundaries. This involves placing one or more microphones near noise sensitive areas so that the sound system operator can monitor sound levels in real time and make any necessary adjustments.

11. Conclusions

11.1 Best Practices in Noise Assessment and Regulation

Basic methodologies and best practices for community noise assessment, environmental acoustics measurements, and noise regulation documents have been discussed. The group of ANSI standards in S12.9 represents the current best practices in community noise assessment. The measurement methodology and sound classifications in Part 4 of the standard (harmonized with International Organization for Standardization standard ISO 1996) have been implemented under European Union Directive 2002/49 and in a number of Asian countries. ANSI S12.9 Parts 4 and 5 have been used as the basis for the recommendations in this document.

11.2 Characteristics of Pickleball Sound

The most notable sounds from pickleball courts are the popping sound produced when a pickleball contacts a paddle and speech. It is the popping sound of the paddle impacts that produces the greatest number of noise complaints. This sound has been classified as highly impulsive for the purpose of noise assessment under ANSI S12.9 Part 4.

11.3 Noise Impact Assessment of Pickleball

It has been shown that averaging techniques such as equivalent-continuous and maximum fast exponential time weighted sound pressure levels (LAeq and LAm_{ax}) are not well suited for assessment of short duration impulsive sound like that produced by the impact of a pickleball on a paddle. These metrics can be expected to substantially underestimate the community response to this type of sound. Measurement procedures based on the adjusted sound exposure level according to ANSI S12.9 Part 4 have been described as a more accurate methodology for noise impact assessment of pickleball.

11.4 Noise Abatement Planning

Setbacks are an important first step in mitigating pickleball courts. A noise abatement plan usually consists of a number of treatments that each contribute a certain amount of noise reduction. Any difference between the total noise reduction of the abatement treatments and that required to meet target sound levels must be made for with setbacks.

Topography and multistory structures near the courts will also influence the amount of setback required. In order for a noise barrier to be effective it must block the line of sight from the sound source to the point of observation. Upper level bedroom windows and decks that are able to overlook the noise barrier will not be shielded and will likely experience a greater noise impact than at ground level.

Testing at numerous pickleball courts has found that the sound radiated from the paddles is directional. More sound goes in the direction of play than to the sides of the court. This characteristic can be used as a noise abatement measure by orienting pickleball courts so that the direction of play is not directed toward noise sensitive areas.

Sound masking in the form of water fountains has been found to be somewhat helpful in certain situations. This is mainly where the masking sound source is much closer to the noise sensitive area than the pickleball courts and the noise sensitive area is not too close to the pickleball courts. Roadways have not been found to be effective masking sources for pickleball.

In most cases, the noise abatement installed for the paddle impacts will be sufficient for speech from the courts as well. Noise complaints about speech on pickleball courts are most often related to content rather than sound level. This is best addressed through policy.

11.5 Site Planning

Site review and feasibility analysis for pickleball begins by looking at available setbacks and sight lines. This will determine what noise abatement treatments may be needed and whether they can be effective on a particular site. Topography and the presence of nearby multistory housing are also important considerations that may affect required setbacks. The noise impact assessment of impulsive sound is a complex task that should be done using modern standards and best practices by an acoustical engineer with experience in psychological acoustics and signal analysis.

References

ANSI S1.4-1983, *Specification for Sound Level Meters*, American National Standards Institute, 1983.

ANSI S1.4-2014, *Electroacoustics – Sound Level Meters – Part 1: Specifications*, American National Standards Institute, 2014.

ANSI S1.11-2004, *Specification For Octave-Band and Fractional-Octave-Band Analog and Digital Filters*, American National Standards Institute, 2004.

ANSI S1.13-2005, *Measurement of Sound Pressure Levels in Air*, American National Standards Institute, 2005.

ANSI S1.42-2001, *Design Response Of Weighting Networks For Acoustical Measurements*, American National Standards Institute, 2001.

ANSI S1.43-1997, *Specifications For Integrating-Averaging Sound Level Meters*, American National Standards Institute, 1997.

ANSI S3.5-1997, *Methods of Calculation of the Speech Intelligibility Index*, American National Standards Institute, 1997.

ANSI S12.9-2013, *Quantities and Procedures for Description and Measurement of Environmental Sound – Part 3: Short-term Measurements with an Observer Present*, American National Standards Institute, 2013.

ANSI S12.9-2021, *Quantities and Procedures for Description and Measurement of Environmental Sound – Part 4: Noise Assessment and Prediction of Long Term Community Response*, American National Standards Institute, 2021.

ANSI S12.9-2007, *Quantities and Procedures for Description and Measurement of Environmental Sound – Part 5: Sound Level Descriptors for Determination of Compatible Land Use*, American National Standards Institute, 2007.

ANSI S12.62-2012, *Attenuation of sound during propagation outdoors – Part 2: General method of calculation*, Nationally Adopted International Standards, Acoustical Society of America (ASA), 2012.

Buchta, Edmund, "A field survey on annoyance caused by sounds from small firearms," *Journal of the Acoustical Society of America*, vol. 88 (3), September 1990. p. 1459.

City of La Cañada Flintridge, "Pickleball Program at Glenhaven Park to End October 28," <<https://cityoflcf.org/pickleball-program-at-glenhaven-park-to-end-october-28/>>, October 27th, 2022.

Dittrich, Kerstin and Oberfeld, Daniel, "A comparison of the temporal weighting of annoyance

and loudness," *Journal of the Acoustical Society of America*, vol. 126 (6), December 2009. p. 3168.

Harris, Cyril M. (Ed.), *Handbook of Acoustical Measurements and Noise Control, 3rd Edition*, Acoustical Society of America, 1998.

ISO 226-2003, *Acoustics - Normal equal-loudness-level contours*, International Organization for Standardization (ISO), 2003.

ISO 1996-1, *Acoustics - Description, measurement and assessment of environmental noise - Part 1: Basic quantities and assessment procedures*, International Organization for Standardization (ISO), 2016.

ISO 9613 Part 2, *Acoustics - Attenuation of Sound During Propagation Outdoors - Part 2: General Method of Calculation*, International Organization for Standardization (ISO), 1996.

Park Cty, Utah, Municipal Code 15-4-22 Outdoor Pickleball Courts In Residential Areas. Adopted April, 2022.

Schultz, T. J., "Synthesis of Social Surveys on Noise Annoyance," *Journal of the Acoustical Society of America* v. 64, pp. 377-405, 1978.

Smooenburg, G. F., Vos, J., "Rating of impulse noise, in particular shooting noise, with regard to annoyance," *Journal of the Acoustical Society of America*, suppl 1, vol. 73, Spring 1983. p. S48.

Vos, Joos, "On the annoyance caused by impulse sounds produced by small, medium-large, and large firearms," *Journal of the Acoustical Society of America*, vol. 109 (1), January 2001. p. 244-253.

Vos, Joos and Houben, Mark M. J., "Enhanced awakening probability of repetitive impulse sounds," *Journal of the Acoustical Society of America*, vol. 134 (3), September 2013. p. 2011.

Vos, Joos and Smooenburg, Guido F., "Penalty for impulse noise, derived from annoyance for impulse and road-traffic sounds," *Journal of the Acoustical Society of America*, vol. 77 (1), January 1985. p. 193.

World Health Organization (WHO), *Night Noise Guidelines for Europe*, <http://www.euro.who.int>, 2009.

Zwicker, E. and Fastl, H., *Psychoacoustics Facts and Models, 2nd Edition*, Springer, 1999.

Kara Tragesser

From: waisty <alens.2009@gmail.com>
Sent: Wednesday, April 17, 2024 12:50 PM
To: Kara Tragesser
Subject: [EXT] Proposed Pickleball Court Installation

Hello Kara,

It has come to my attention that our neighboring corporate entity (R&R Realty/Arcadia Building) is planning to install two outdoor pickleball courts as part of their ongoing building renovation project. Community development is welcome, but pickleball courts are a significant concern due to the potential noise pollution impact on our peaceful neighborhood.

Pickleball can be alarmingly loud, reaching levels that may disrupt our daily lives. Depending on the distance, the noise can reach 70 dBA or higher (even up to 85 dBA)- louder than the volume of a vacuum cleaner. This is significantly louder than the usual outdoor background noise, which is around 55 dBA.

The annoyance from pickleball noise isn't just about volume. The high pitch of the paddle hitting the ball and the unpredictable, rapid tempo of the game contribute to the disturbance. These elements combine to create a repetitive, impulsive sound that can be particularly irritating as the human ear is especially sensitive to the frequencies produced by the pickleball "pop", making the perceived loudness even worse and for me working remotely creates additional noise which will interrupt my work. In addition, there may also be a financial impact as research has shown pickleball noise may even negatively impact property values by 10 to 20%.

This is a very serious matter and I hope that this writing and concern will stop the proposed plans going forward which are affecting a whole community.

Thank you.

ARCADIA EXTERIOR AMENITIES MINOR MODIFICATION SITE PLAN

Country Club Office Plaza, Lot 7
7000 Vista Drive

City of West Des Moines, Dallas County, Iowa

LEGEND

FEATURES	EXISTING	PROPOSED
PI, PC, PT, POT, POST		
Bench Mark		
Section Corner		
Iron Monument		
ROW Marker		
ROW Rail		
Easement Line		
Property Line		
Right-of-Way Line		
Corporate Line		
Fence (Barbed, Field, Hog)		
Fence (Chain Link)		
Fence (Wood)		
Fence (Decorative w/ Pillars)		
Tree Line		
Bush		
Coniferous Tree		
Deciduous Tree		
Bush To Be Removed		
Coniferous Tree To Be Removed		
Deciduous Tree To Be Removed		
Building Setback line		
Parking Lot Setback line		
Underground Telephone		
Underground Electric		
Overhead Electric		
Underground Television		
Overhead Television		
Water Main		
Sanitary Sewer		
Fiber Optic		
Storm Sewer		
Gas main		
Storm sewer Manhole		
Storm Sewer Intake		
Sanitary sewer Manhole		
Fire Hydrant		
Area Intake		
Water Valve		
Telephone Pole		
Telephone Pedestal		
Guy Anchor		
Power Pole with Light		
Power Pole		
Light Pole		
Traffic Signal		
Gas Valve		
Water Well		
Mail Box		
Soil Boring		
Utilize as Constructed		
Not in Contract		
Proposed Sidewalk 4"		
Proposed Paving 6"		

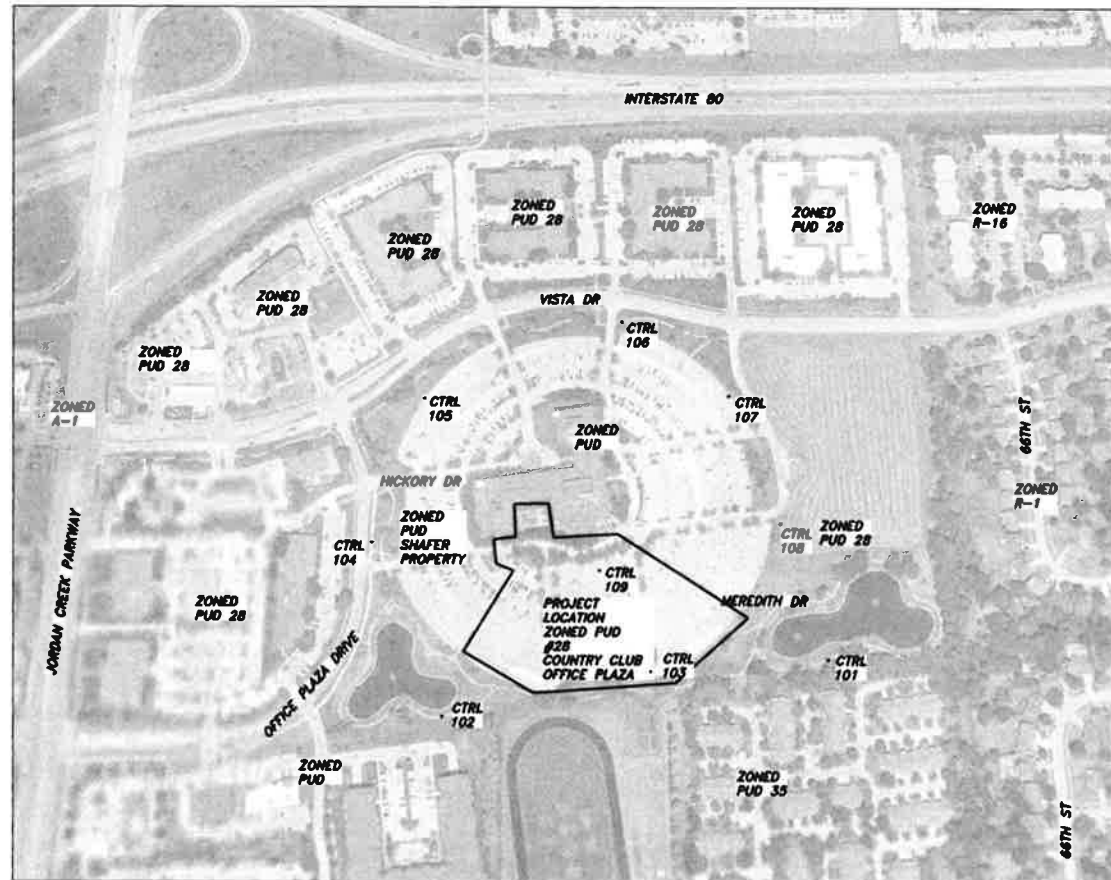

OWNER/DEVELOPER
DALLAS COUNTY PARTNERS II
1080 JORDAN CREEK PARKWAY, SUITE 200 NORTH
WEST DES MOINES, IA 50266
PHONE 515-974-5460
CONTACT: JEREMY SHEPHERD
EMAIL: SHEPHERD.JEREMY@RRREALTY.COM

ENGINEER / SURVEYOR
KIRKHAM MICHAEL
CONTACT: GREG D CABALKA
4390 114TH STREET
URBANDALE, IOWA 50322
PHONE 515-393-4777
EMAIL: GCABALKA@KIRKHAM.COM

LANDSCAPE ARCHITECT
BSB DESIGN
CONTACT: TERRY SMITH
220 N. SMITH STREET, SUITE 210
PALATINE, IL 60067
PHONE 847-705-2200
EMAIL: TSMITH@BSBDESIGN.COM

SITE ADDRESS
7000 VISTA DRIVE
WEST DES MOINES, IA 50323

PROPERTY DESCRIPTION
LOT 7, COUNTRY CLUB OFFICE PLAZA, AN OFFICIAL PLAT NOW IN AND FORMING PART OF THE CITY OF WEST DES MOINES, DALLAS COUNTY, IOWA.

SITE CONTAINS 34.25 ACRES
100 YEAR FLOOD PLAIN
THE ENTIRE SITE IS ZONE X, AREAS DETERMINED TO BE OUTSIDE THE 0.2% ANNUAL CHANCE FLOOD PLAIN AS SHOWN ON FLOOD INSURANCE RATE MAP
COMMUNITY PANEL NUMBER 190231 0310 F
EFFECTIVE ON 02/01/2019
VERSION 2.2.2.1
MAP NUMBER 19153C0310F
NO MINIMUM OPENING SPECIFIED

VICINITY MAP
NOT TO SCALE

SCHOOL DISTRICT
WEST DES MOINES

CONSTRUCTION SCHEDULE
START SPRING 2024 WITH COMPLETION FALL 2024

PROPOSED USE
OFFICE SPACE

SITE PLAN INFORMATION			
FROM ORIGINAL SITE PLAN	MODIFICATIONS TO ORIGINAL	FINAL WITH MODIFICATIONS	
OPEN SPACE REQUIRED	608,696.35 S.F.	0.00 S.F.	608,696.35 S.F.
OPEN SPACE PROVIDED	751,969.50 S.F.	-170,013.00 S.F.	921,982.50 S.F.
TOTAL PAVEMENT AREA	712,748.50 S.F.	-170,013.00 S.F.	542,735.5 S.F.
FIRST FLOOR BUILDING AREA	70,772.00 S.F.	0.00 S.F.	70,772 S.F.
TOTAL SITE AREA	1,535,490.00 S.F.	0.00 S.F.	1,535,490 S.F.
TOTAL SITE AREA	35.25 AC	0.00 AC	35.25 AC
PARKING SPACES			
FROM ORIGINAL SITE PLAN	MODIFICATIONS	FINAL WITH MODIFICATIONS	
TOTAL # STALLS REQUIRED	1022	0	1022
TOTAL STALLS PROVIDED WADA	1817	-544	1273
ADA STALLS REQUIRED	28	-5	23
ADA STALLS PROVIDED	28	-5	23

GENERAL NOTES:

1. The 2023 edition of the Urban Standard Specifications for Public Improvements, Including City of West Des Moines supplemental Specifications, and City of West Des Moines Water Utility Specifications shall apply to all work on this project except modified herein. These specifications may be obtained by contacting:

The Institute for Transportation
2711 South Loop Drive, Suite 4700
Ames, IA 50010-8564
Ph: 515-294-8103

These specifications are also available on-line at: www.iowasudas.org

- THIS DESIGN SPECIFICALLY PREPARED FOR USE AT THE LOCATION SHOWN. USE IN ANY OTHER MANNER EXCEEDS THE INTENDED PURPOSE OF THESE DRAWINGS AND ANY ACCOMPANYING SPECIFICATIONS.
- UTILITY WARNING:
THE UTILITIES SHOWN HAVE BEEN LOCATED FROM FIELD SURVEY INFORMATION AND / OR RECORDS OBTAINED. THE SURVEYOR MAKES NO GUARANTEE THAT THE UTILITIES SHOWN COMPRISE ALL SUCH UTILITIES IN THE AREA, EITHER IN SERVICE OR ABANDONED. THE SURVEYOR FURTHER DOES NOT WARRANT THAT THE UTILITIES SHOWN ARE IN THE EXACT LOCATION INDICATED. VERIFY LOCATION OF ALL UTILITIES BEFORE CONSTRUCTION.
- STRIP, SALVAGE, AND RESPREAD 8" MINIMUM. REFER TO SUDAS SPECIFICATION 2010-2.01
- NOTIFY ENGINEER AND CITY OF WEST DES MOINES AT LEAST 48 HOURS PRIOR TO BEGINNING WORK.
- BACKFILL WITH SUITABLE MATERIAL AND COMPACT TO 95% MAXIMUM DENSITY PER SUDAS.
- ADJUSTMENT OF EXISTING UTILITY APPURTENANCES TO FINAL GRADE IS CONSIDERED INCIDENTAL TO THE SITE WORK.
- ALL FIELD TILES ENCOUNTERED DURING CONSTRUCTION SHALL BE RECONNECTED AND NOTED ACCORDINGLY ON THE AS-BUILT DOCUMENTS.
- DIMENSIONS, BUILDING LOCATION, UTILITIES AND GRADING OF THIS SITE ARE BASED ON INFORMATION AVAILABLE AT THE TIME OF LAYOUT. DEVIATIONS MAY BE NECESSARY IN THE FIELD ANY SUCH CHANGES OR CONFLICTS BETWEEN THIS PLAN AND FIELD CONDITIONS ARE TO BE REPORTED TO THE ARCHITECT/ENGINEER PRIOR TO STARTING CONSTRUCTION.
- THE SITE CONTRACTOR SHALL BE RESPONSIBLE FOR VERIFICATION OF ALL DIMENSIONS PRIOR TO STARTING WORK.
- ALL CONSTRUCTION WITHIN PUBLIC R.O.W./EASEMENTS, AND/OR ANY CONNECTION TO PUBLIC SEWERS AND STREETS, SHALL COMPLY WITH THE WEST DES MOINES STANDARD CONSTRUCTION SPECIFICATIONS FOR SUBDIVISIONS, DSM METRO DESIGN STANDARDS AND WDM ADDENDUMS.
- AT LEAST ONE WEEK PRIOR TO ANY CONSTRUCTION WITHIN PUBLIC R.O.W./EASEMENTS AND/OR ANY CONNECTION TO PUBLIC SEWERS AND STREETS, THE CONTRACTOR SHALL CONTACT THE WDM ENGINEERING SERVICES 222-3475 TO SCHEDULE ANY REQUIRED INSPECTIONS. IT IS IMPORTANT TO NOTE CITY APPROVAL OF THIS PLAN IS SUBJECT TO THE APPLICANT OBTAINING ALL NECESSARY EASEMENTS/AGREEMENTS AND APPLICABLE PERMITS.

CONTROL POINTS:

#	DESCRIPTION (SEE VICINITY MAP FOR APPROXIMATE LOCATIONS)	FOUND	NORTHING	EASTING	ELEVATION
101	S. SIDE, W. END, E. POND IN PED. TRAIL	CUT X	578400.95	1558034.09	201.56
102	S. SIDE, E. END, W. POND IN PED. TRAIL	CUT X	578264.41	1556959.45	210.14
103	S. SIDE PARKING LOT MIDDLE OF DBL INTAKE	CUT X	578380.82	1557541.64	210.78
104	E. EDGE SIDEWALK 50' N. OF W. ACCESS DRIVE FROM OFFICE PLAZA DR	CUT X	578754.23	1556781.13	218.32
105	NW SIDE SITE ON OUTER SIDEWALK	CUT X	579220.44	1556913.19	214.02
106	N SIDE SITES ON OUTER SIDEWALK	CUT X	579431.65	1557473.21	204.19
107	NE SIDE OF SITE ON OUT SIDEWALK	CUT X	579229.34	1557774.40	213.22
108	SE. OF E/W. ACCESS DRIVE IN GRASS	5/8" REBAR	578798.09	1557938.26	210.82
109	PARKING LOT S. SIDE BUILDING 1ST E/W DRIVE ISLE	CUT X	578663.34	1557386.69	215.68

BENCHMARKS:

CITY
BM-122 NORTHEAST CORNER OF ASHWORTH ROAD AND 63RD STREET, NORTHWEST CORNER OF SIDEWALK JUNCTION, 1 FOOT WEST OF NORTH-SOUTH SIDEWALK, 1 FOOT NORTH OF EAST-WEST SIDEWALK/BIKE PATH, 11 FEET EAST OF BACK OF CURB
WDM DATUM - FEET 220.62
NORTHING 577321.4
EASTING 1559850.8

INDEX OF SHEETS

G 0.1 COVER SHEET	C 1.0 GRADING PLAN
L 0.1 Site Removals Plan	C 1.1 GRADING PLAN
L 1.1 Overall Site Plan	C 1.2 GRADING PLAN
L 1.2 South Entry/ Plaza Site Plan	C 1.3 NORTH VESTIBULE GRADING AND REMOVALS
L 1.3 South Entry/ Plaza Grading Plan	C 2.0 STORM SEWER PLAN
L 1.4 Enlarged Plaza Layout Plan	C 3.0 DETAILS
L 1.5 Site Landscape Plan	C 3.1 DETAILS
L 1.6 South Entry/ Plaza Landscape Plan	
L 1.7 Landscape Grading Plan	
L 1.8 Landscape Details/ Plant List	
L 1.9 Site Details	
L 1.10 Site Details	

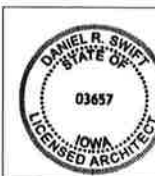

PAGES OR SHEETS COVERED BY THIS SEAL:
L 0.1, L 1.1, L 1.2, L 1.3, L 1.4, L 1.5,
L 1.6, L 1.7, L 1.8, L 1.9, L 1.10

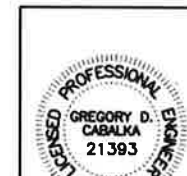

I HEREBY CERTIFY THAT THIS ENGINEERING DOCUMENT WAS PREPARED BY ME OR UNDER MY DIRECT PERSONAL SUPERVISION AND THAT I AM A DULY LICENSED PROFESSIONAL ENGINEER UNDER THE LAWS OF THE STATE OF IOWA.

GREGORY D. CABALKA, PE DATE _____
LICENSE NO. 21393
PAGES OR SHEETS COVERED BY THIS SEAL:
G 0.1, C 1.0, C 1.1, C 1.2, C 1.3, C 2.0, C 3.0, C 3.1



REMOVALS LEGEND

	CONCRETE CURB TO BE REMOVED 5,736 LF
	CONC. PKG. LOT PVT, TO BE REMOVED 176,400 SF
	CONC. SIDEWALK PVT, TO BE REMOVED 4,500 SF
	EXISTING TREES TO BE REMOVED
	EXISTING TREES TO REMAIN WITH TREE PROTECTION
	EXISTING RET. WALL TO BE REMOVED 396 LF
	EX. PKG LOT LIGHTS TO BE REMOVED

CONTRACTOR TO VERIFY ALL QUANTITIES REMOVAL INDICATED

MODIFIED CANOPY STRUCTURE
SAWCUT PAVEMENT LINE (SHOWN AS
DASHED LINE) AT JOINT LINE

REMOVE PORTION OF CONCRETE PAD
AT STAIR LANDING

REMOVE EXISTING STEPS, WALLS AND CONCRETE IN COURTYARD.
REMOVE ALL BOULDER STONE, REMNANTS OF FOUNTAIN, PIPING,
PLUMBING AND FOUNTAIN STRUCTURE. CONTRACTOR SHALL ALSO
IDENTIFY REMOVAL LIMITS FOR ANY IRRIGATION AND PLUMBING AND
COORDINATE WITH OWNER.
MAINTAIN SHRUB HEDGE AND EXISTING CONCRETE PAVEMENT UNDER
THE BUILDING CANOPY

SAWCUT PAVEMENT LINE (SHOWN AS
DASHED LINE) AT JOINT LINE

MAINTAIN AND PROTECT EXISTING
SHRUB HEDGE

REMOVE EXISTING FENCE AND
PROVIDE SALVAGED METAL FENCE
MATERIAL TO OWNER

RELOCATE EXISTING MAILBOX
COORDINATE WITH OWNER

EX. LIGHT TO REMAIN

EX. LIGHT TO REMAIN

EX. LIGHT TO REMAIN

EX. LIGHT TO REMAIN

EX. LIGHT TO REMAIN

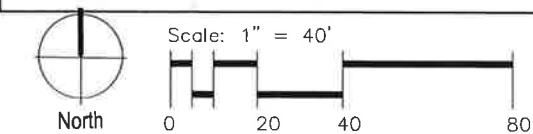

ISSUE DATE: 02-21-2024

REVISIONS	DATE	BY	CHKD
02/21/2024			

City Comments



Arcadia Exterior Amenities
7000 Vista Drive
West Des Moines, IA 50266



4601 Westown Parkway, Suite 208
West Des Moines, Iowa 50266
515.273.3020

JOB NO: LP230292-00 PROJ/MGR: SG
DRAWN: TJS CHECKED: -
SITE REMOVALS PLAN

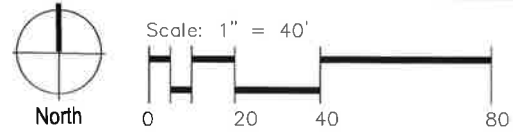
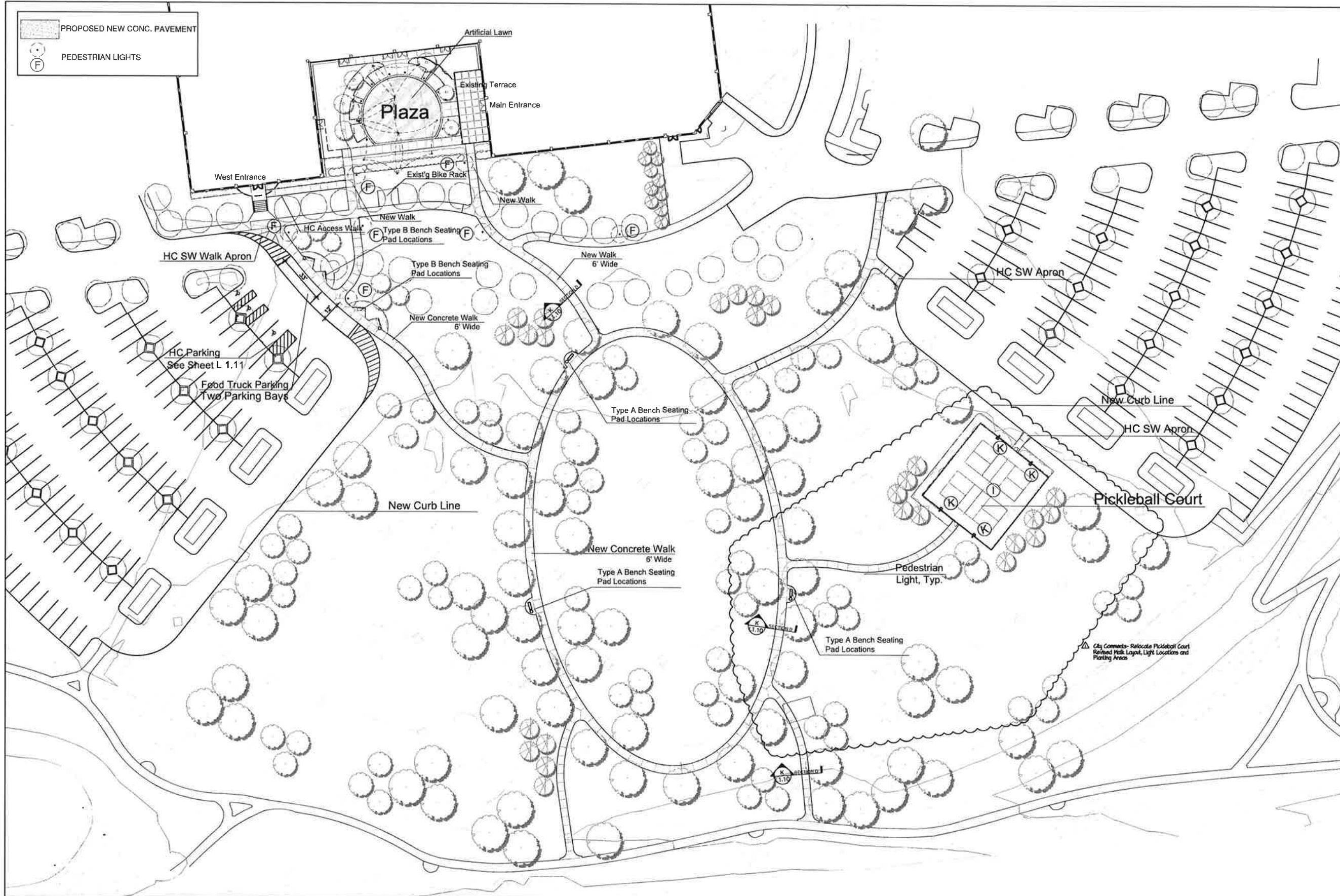

ISSUE DATE: 05-21-2024

REVISIONS	DATE	BY	CHKD
02/27/24			

City Comments



Arcadia Exterior Amenities
7000 Vista Drive
West Des Moines, IA 50266



4601 Westown Parkway, Suite 208
West Des Moines, Iowa 50266
515.273.3020

JOB NO: LP30292.00 PROJ MGR: BG
DRAWN: LJS CHECKED: --
OVERALL SITE PLAN

L1.1

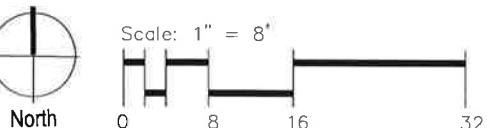
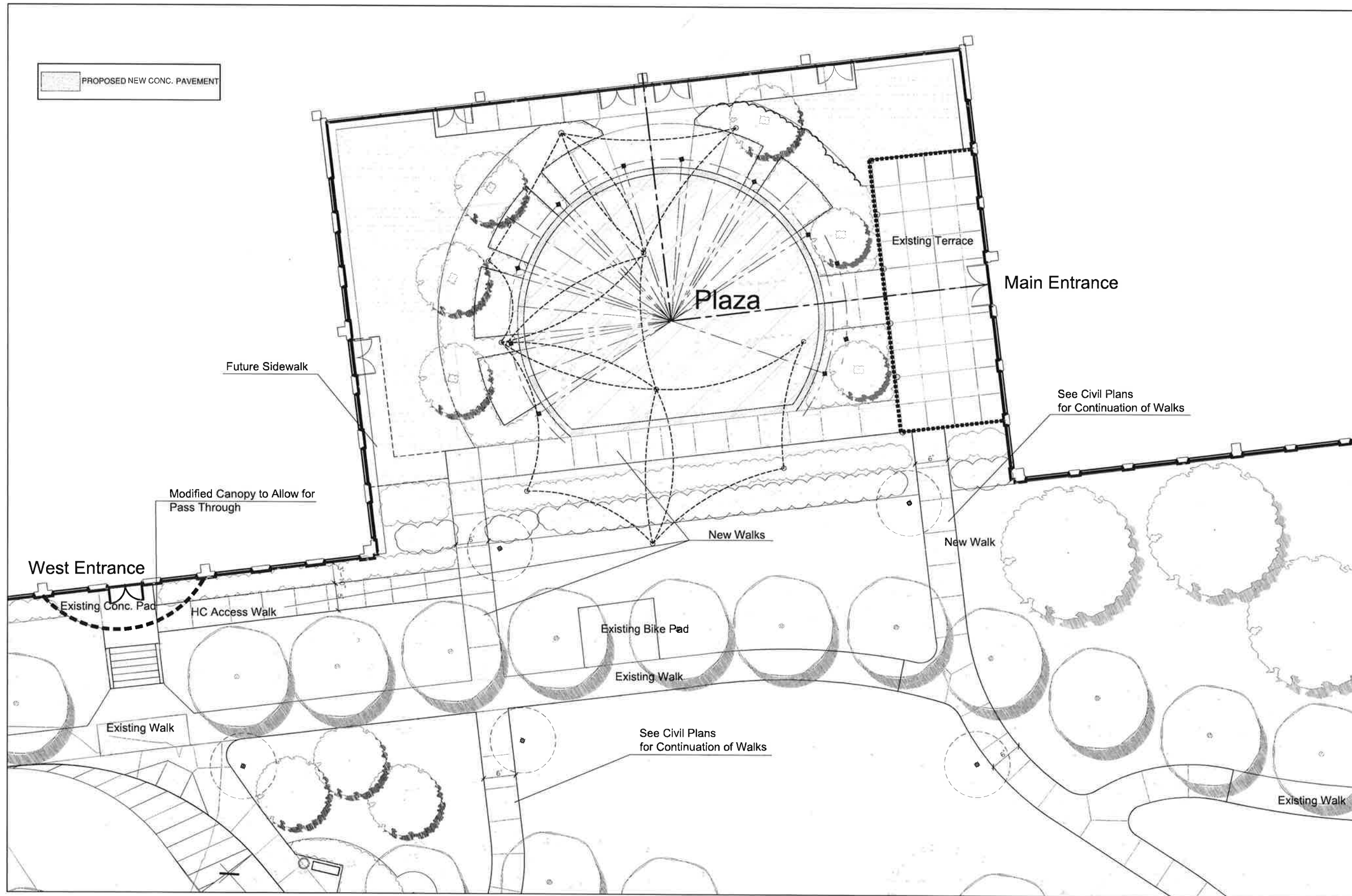

ISSUE DATE: 02-21-2024

REVISIONS	DATE	BY	CHKD
02/21/2024		JUS	SG

SEE CIVIL PLANS FOR CONTINUATION OF WALKS



Arcadia Exterior Amenities
7000 Vista Drive
West Des Moines, IA 50266



4601 Westown Parkway, Suite 208
West Des Moines, Iowa 50266
515.273.3020

JOB NO: L7232292.00 PROJ MGR: SG
DRAWN: TJS CHECKED: -
SOUTH ENTRY / PLAZA SITE PLAN

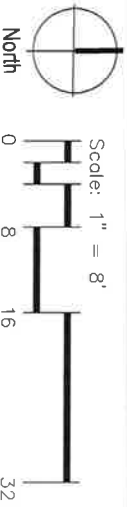

HARDSCAPE MATERIAL LEGEND

TAG NO.	MATERIAL NAME	QUANTITY
A	BACK DROP OUTDOOR OFFICES	2
B	GAS FIRE PIT (PORTABLE)	2
C	SIX FOOT SWINGING BENCH	2
D	MOVEABLE TABLES/CHAIRS	3 / 12
E	SHADE STRUCTURE	1 SYSTEM
F	PEDESTRIAN LIGHTS - 12-14"	7
G	AMERICANA CHAIRS	4
H	ARTIFICIAL LAWN SURFACE	2,590 SF
I	PICKLEBALL COURTS	2
J	BOLLARD LIGHTS	11
K	PICKLEBALL COURT LIGHTS	4

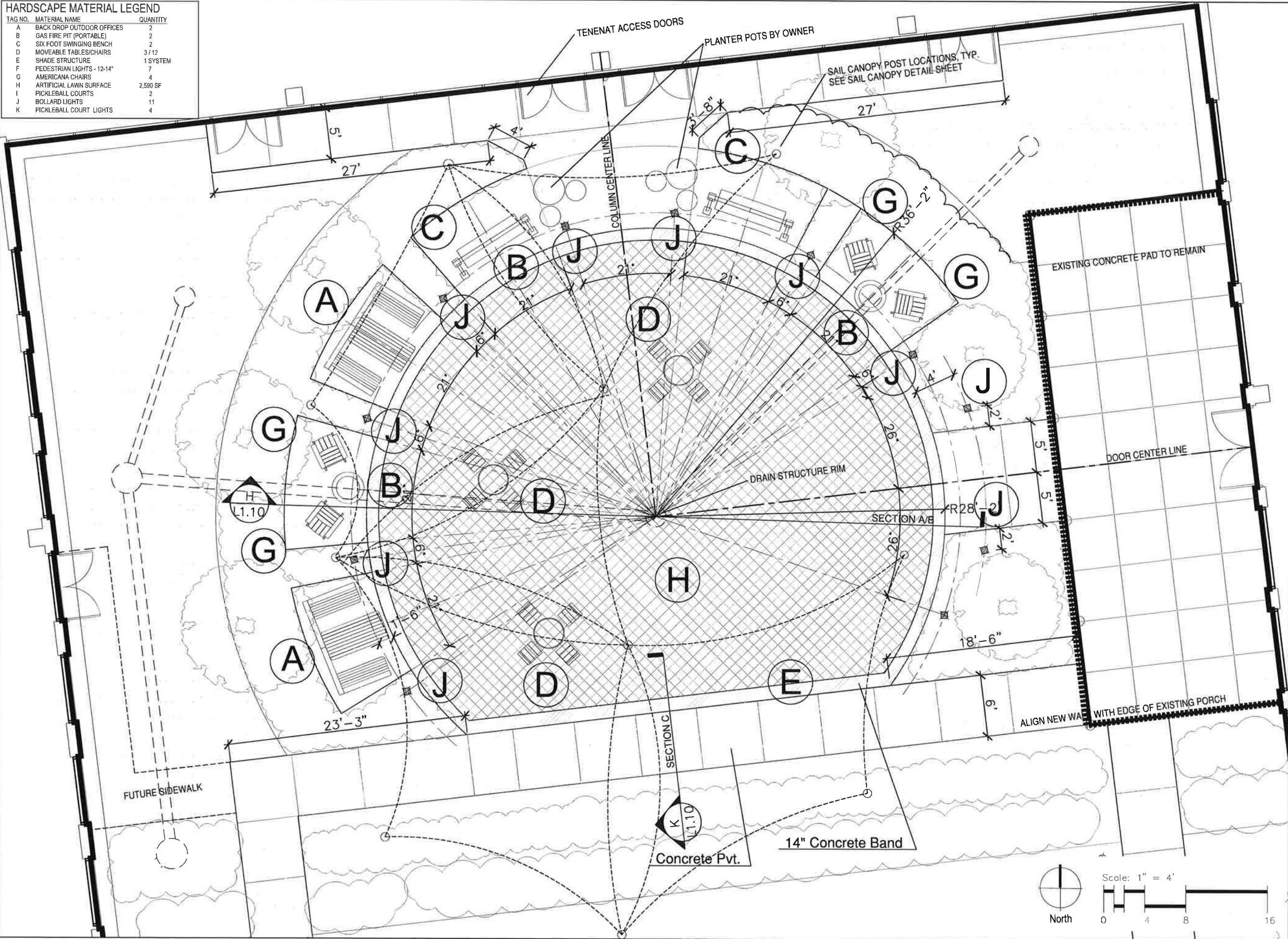

ISSUE DATE: 02-21-2024

REVISIONS	BY	DATE
001	TJS	02/21/24

City Comments



Arcadia Exterior Amenities
 7000 Vista Drive
 West Des Moines, IA 50266









4601 Westown Parkway, Suite 200
 West Des Moines, Iowa 50266
 515.273.3020

JOB NO: LP230293.00 PROJ MGR: SIS
 DRAWN: TJS CHECKED: -
 ENLARGED PLAZA LAYOUT PLAN

L1.4

LEGEND

-  EXISTING TREES TO REMAIN
-  PROPOSED SHADE TREES
-  PROPOSED INTERMEDIATE TREES
-  PROPOSED EVERGREEN TREES
-  PROPOSED DECIDUOUS/EVERGREEN SHRUBS
-  PROPOSED GROUNDCOVER/PERENNIAL PLANTINGS
-  PROPOSED ORNAMENTAL GRASSES

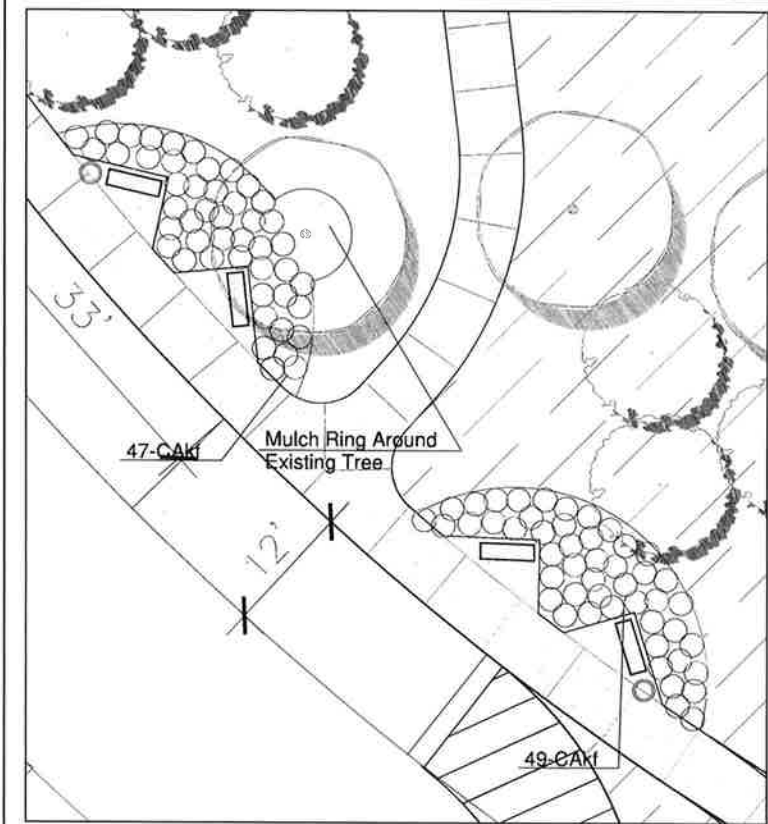

1 BENCH PAD AREAS
SCALE: 1/8" = 1'-0"

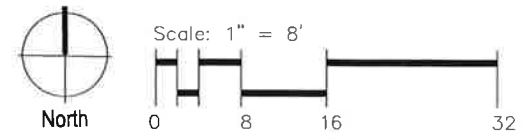
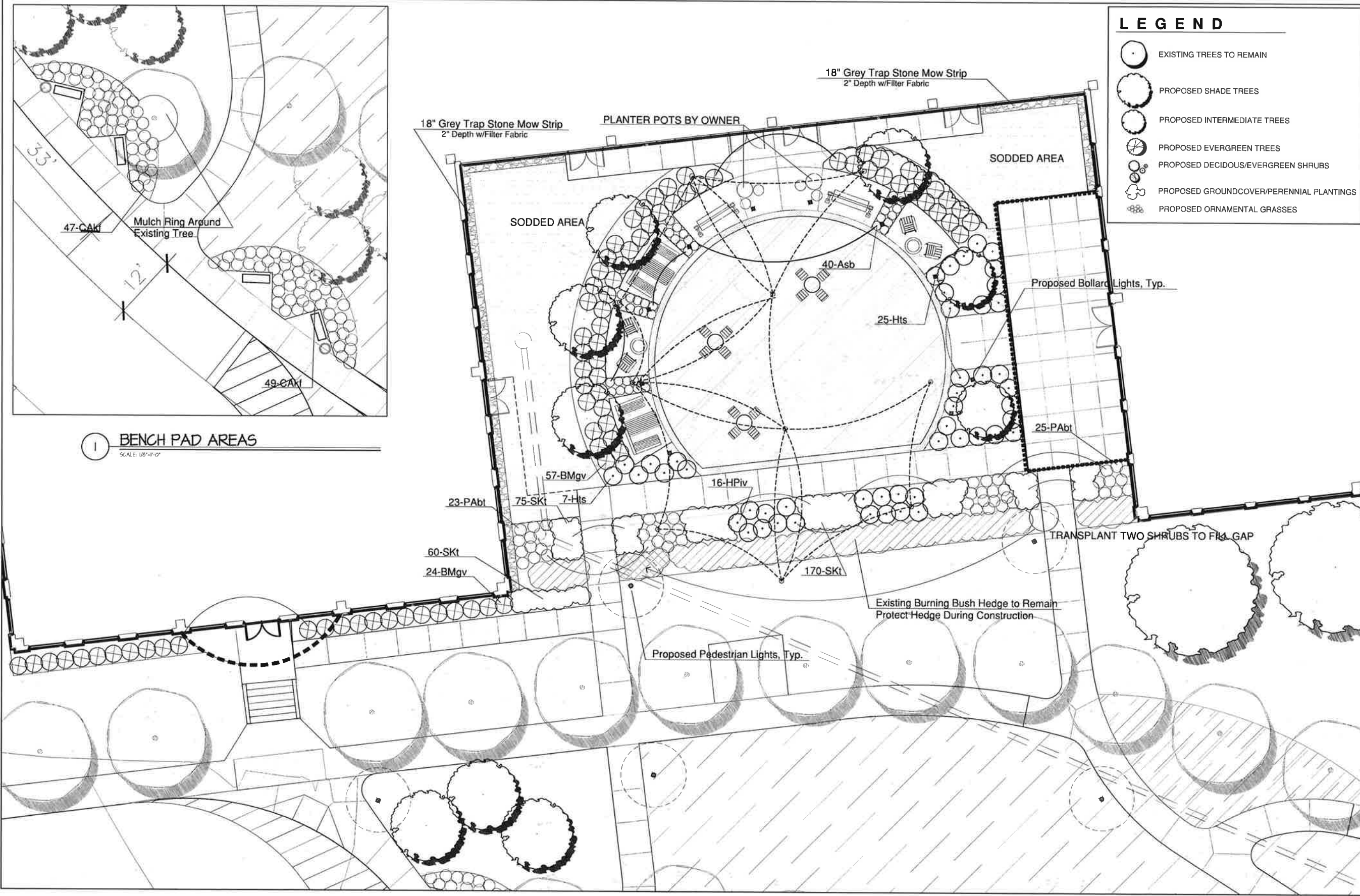

ISSUE DATE: 02-21-2024

REVISIONS	DATE	BY	CHK
02/21/2024			

1500 Jordan Creek Parkway
West Des Moines, IA 50266
PH: 515.281.4500



Arcadia Exterior Amenities
7000 Vista Drive
West Des Moines, IA 50266



4601 Westown Parkway, Suite 205
West Des Moines, Iowa 50266
515.273.3020

JOB NO: LP230292.00 PROJ MGR: SG
DRAWN: TJS CHECKED: -
5TH ENTRY PLAZA L'SCAPE PLAN

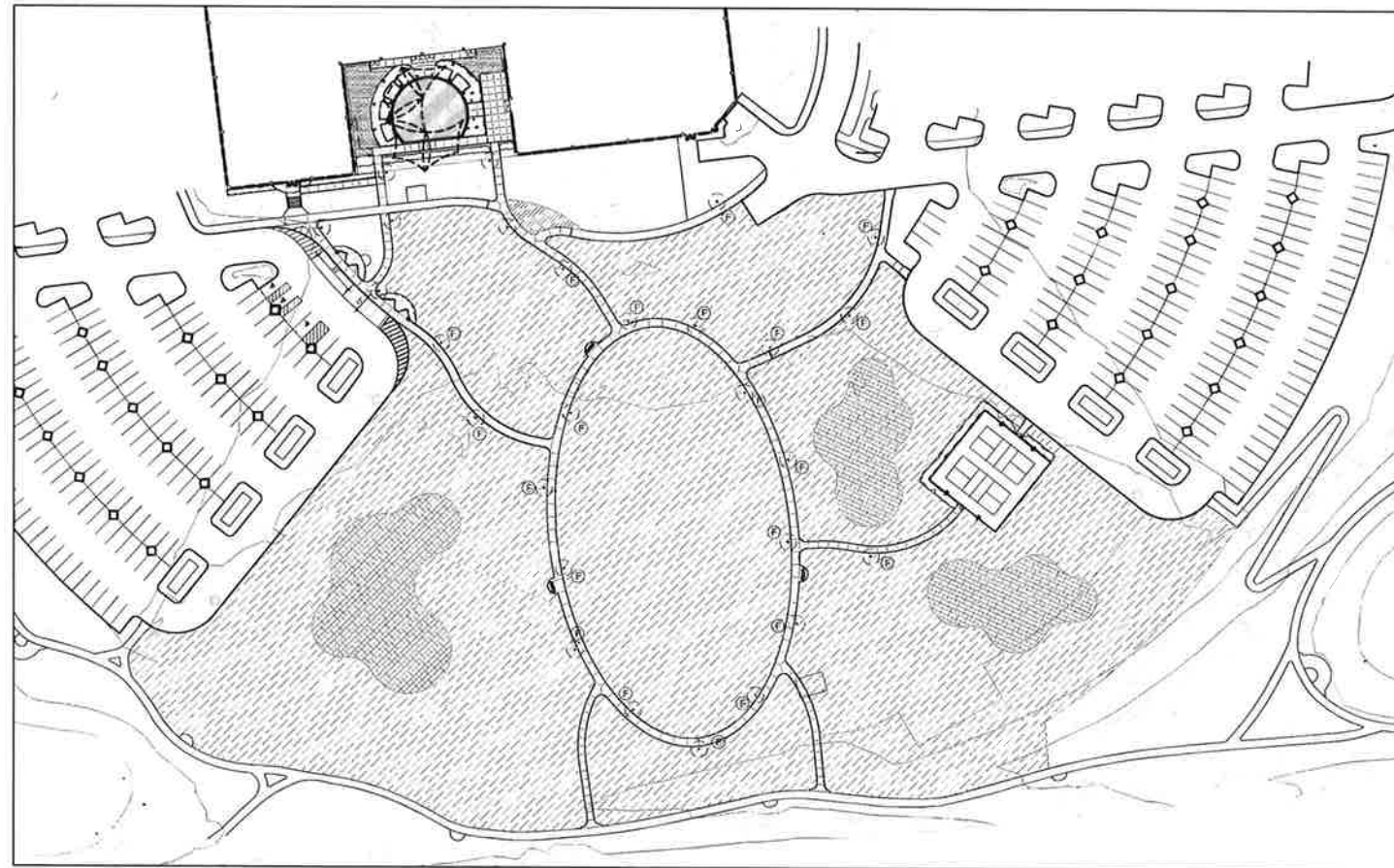

2 LANDSCAPE TURF AREAS
SCALE: 1"=60'

LEGEND

- SEEDED LAWN AREAS - PREPARE SEED BED TO HAVE A MINIMUM OF 12" OF TOPSOIL DEPTH
- LOW PROFILE NATIVE SEED MIX
- SODDED AREAS

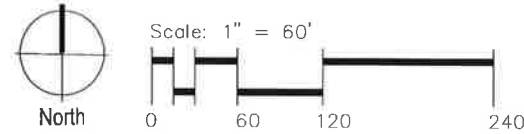

PLANT LIST				
SHADE TREES				
QTY.	KEY	SCIENTIFIC NAME	COMMON NAME	SIZE
6	AFm	Acer rubrum 'Autumn Blaze'	Autumn Blaze Maple	3.0" BB
4	CO	Celtis occidentalis 'Ultra'	Ultra Hackberry	3.0" BB
23	GTs	Gleditsia tricanthos inermis 'Skyline'	Skyline Honey Locust	3.5" BB
2	LT	Liriodendron tulipifera	Tulip Tree	3.0" BB
3	PLa	Platanus acerifolia	London Planetree	3.0" BB
4	QB	Quercus bicolor	Swamp White Oak	3.0" BB
6	QI	Quercus imbricaria	Shingle Oak	3.0" BB
17	QRu	Quercus rubra	Red Oak	3.0" BB
2	TD	Taxodium distichum	Bald Cypress	3.0" BB
7	TCc	Tilia cordata 'Coralithian'	Corinthian Littleleaf Linden	3.0" BB
9	TH	Tilia heterophylla	Beehive Linden	3.0" BB
3	UAp	Ulmus americana 'Patriot'	Patriot Elm	3.0" BB

INTERMEDIATE AND EVERGREEN TREES				
QTY.	KEY	SCIENTIFIC NAME	COMMON NAME	SIZE
2	AC	Amelanchier canadensis	Servicberry	8' CL BB
4	CCA	Carpinus caroliniana	Muscadewood	2.5" BB
17	CC	Cercis canadensis- Standard Trunk	Red Bud	2.5" BB
8	AG	Acre ginnala	Amur Maple	8' BB
9	SRI	Syringa reticulata 'Ivory'- Standard Trunk	Ivory Tree Lilac	2.0" BB
9	MdW	Malus 'Donald Wyman'	Donald Wyman Crab	2.5" BB
9	MF	Malus floribunda	Floribunda Crab	2.5" BB
6	Mps	Malus 'Prairie Snow'	Prairie Snow Crab	2.5" BB
11	Mrr	Malus 'Royal Raindrops'	Royal Raindrop's Crab	2.5" BB
3	OV	Ostrya virginiana	American Hop-Hornbeam	2.5" BB
15	ACo	Abies concolor	Concolor Fir	10' HT BB
10	PA	Picea abies	Norway Spruce	10' HT BB
10	PAC	Picea abies 'Cupressina'	Columar Spruce	8' HT BB

SHRUBS				
QTY.	KEY	SCIENTIFIC NAME	COMMON NAME	SIZE
81	BMW	Buxus microphylla 'Green Velvet'	Green Velvet Boxwood	5 Gal Cont.
16	HPiv	Hydrangea paniculata 'Ivoblo'	Bobo Hydrangea	5 Gal Cont.
32	Hts	Hydrangea 'Tuff Stuff'	Tuff Stuff Hydrangea	3 Gal Cont.
6	POs	Physocarpus opulifolius 'Seward'	Seward Nine Bark	5 Gal Cont.
30	SMp	Syring mysyrenii 'Palabli'	Palabli Lilac	5 Gal Cont.

PERENNIALS AND GROUNDCOVER				
QTY.	KEY	SCIENTIFIC NAME	COMMON NAME	SIZE
86	CAKf	Calamagrostis acutiflora 'Karl Foerster'	K Foerster Feather Reed Grass	1 Gal. 18" On Center
6	CMid	Carex monowa 'Ice Dance'	Ice Dance Sedge	1 Qt. Cont. 18" On Center
40	AaB	Allium 'Summer Beauty'	Summer Beauty Onion	1 Qt. Cont. 18" On Center
6	PVs	Panicum virgatum 'Shenandoah'	Shenandoah Switch Grass	1 Gal. 24" On Center
48	PABt	Pennisetum alopecuroides 'Bunny Tail'	Bunny Tail Fountain Grass	1 Gal. 15" On Center
305	SKL	Sedum kamtschaticum 'Tekardake'	Tekardake Sedum	1 Qt. Cont. 12" On Center

ISSUE DATE: 02-21-2024

REVISIONS	DATE	BY	DESCRIPTION
02/21/24			



Arcadia Exterior Amenities
7000 Vista Drive
West Des Moines, IA 50266



4501 Westown Parkway, Suite 208
West Des Moines, Iowa 50266
515.273.3020

JOB NO: LP202302.00 PROJ. NO: 56
DRAWN: TJS CHECKED: -
LANDSCAPE GRASSING PLAN



Backdrop wood, horizontal slat, no light Scale: NONE

Backdrop wood, no light Scale: NONE

Backdrop table, pergola, deck, no, wood Scale: NONE

CONFIDENTIAL DRAWING INFORMATION CONTAINED HEREIN IS THE PROPERTY OF LANDSCAPE FORMS. IT IS TO BE USED ONLY FOR THE PROJECT AND SITE SPECIFICALLY IDENTIFIED HEREIN. IT IS NOT TO BE REPRODUCED, COPIED, OR TRANSMITTED IN ANY FORM OR BY ANY MEANS, WITHOUT THE WRITTEN CONSENT OF LANDSCAPE FORMS. ALL RIGHTS RESERVED.

A OUTDOOR OFFICE LANDSCAPE FORMS BACKDROP
SCALE: NONE

SIENNA FIRE PIT
CPT 40131
CPT 40131/01

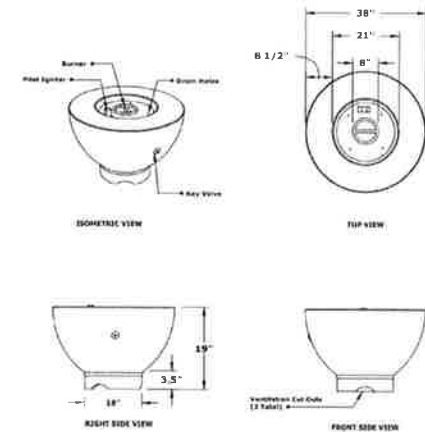

110V Electronic Ignition
ANSI Z39.15.2015, F154.21.1.2015

37" SIENNA FIRE PIT
OF 37" CONCRETE
Model: 37P-010000-001-LP

Color Selection Chart

B 37" DIAMETER GAS FIRE PIT
SCALE: NONE

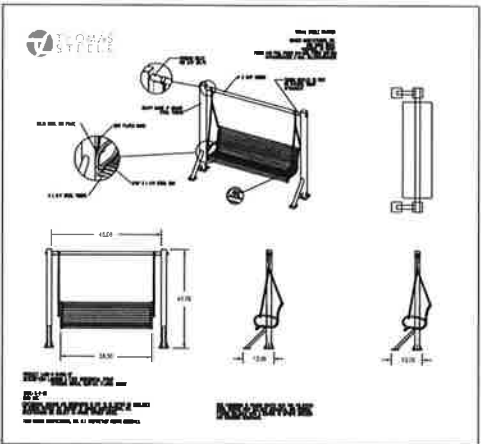

C SIX FOOT SWINGING BENCH
SCALE: NONE

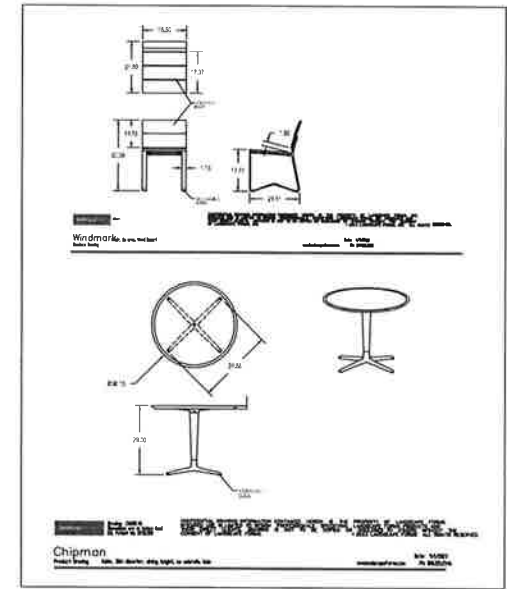

D MOVEABLE TABLE AND CHAIRS
SCALE: NONE



Contractor shall Provide Design-Build Proposal for Shade Sail Assembly Per Post Spacing and Overall Character Indicated on the Site Plan and Performance Specification Provided By Owner

E 3 PT SAIL SYSTEM SHADE STRUCTURE SYSTEM
SCALE: NONE

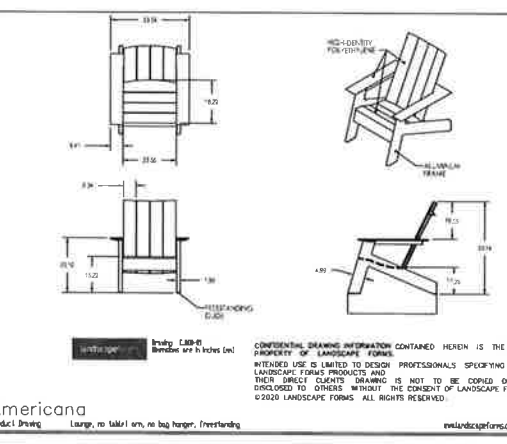

G AMERICANA ADIRONDACK CHAIR
SCALE: NONE

Side View, Front View

PEDESTRIAN LIGHT
SCALE: NONE

By: Sternberg Lighting

Side View, Front View

LIGHT BOLLARD
SCALE: NONE

Local Rep: Jason Odefey, LC
CSLA
Direct 515.650.8119
Mobile 515.979.7298
centralsaleslightingalliance.com

Side View, Front View

PICKLEBALL COURT LIGHTS
SCALE: NONE

Local Rep: Jason Odefey, LC
CSLA
Direct 515.650.8119
Mobile 515.979.7298
centralsaleslightingalliance.com

K PICKLEBALL COURT LIGHTS
SCALE: NONE

ISSUE DATE: 08-27-2024

REVISIONS	City Comments
00270004	



Arcadia Exterior Amenities
7000 Vista Drive
West Des Moines, IA 50266



4001 Westown Parkway, Suite 208
West Des Moines, Iowa 50266
515 273 3820

JOB NO: LP230929-00 PROJ MGR: SB
DRAWN: TJS CHECKED: ...
SITE DETAILS

L1.9

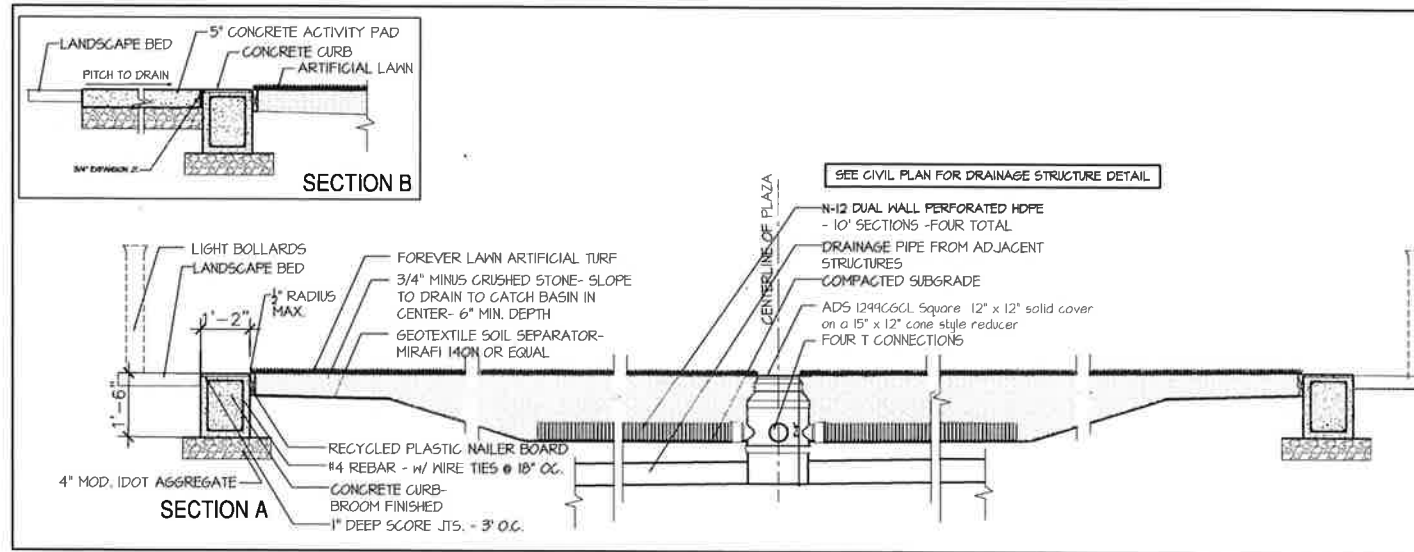

H ARTIFICIAL LAWN SURFACE
SCALE: NONE



Ja TYPE A BENCH /TRASHERS
SCALE: NONE

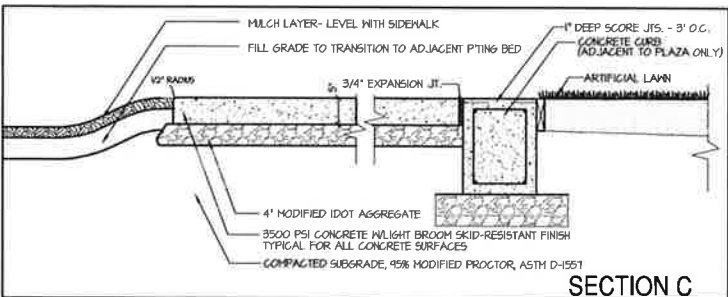

K PLAZA ENTRANCE WALK SECTION
SCALE: 3/4\"/>

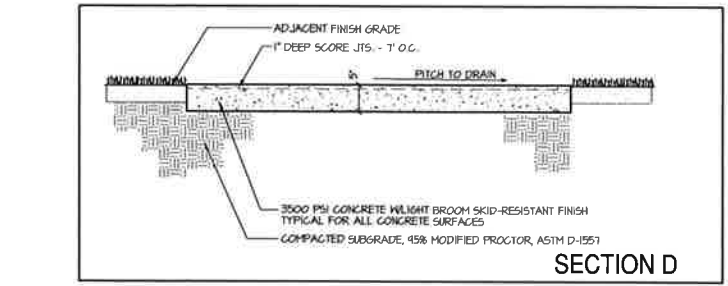

L SITE SIDEWALK SECTION, TYP.
SCALE: 3/4\"/>



Jb TYPE B BENCH
SCALE: NONE

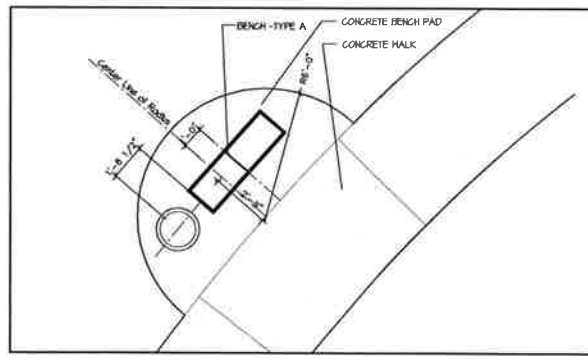

TYPE A BENCH PAD

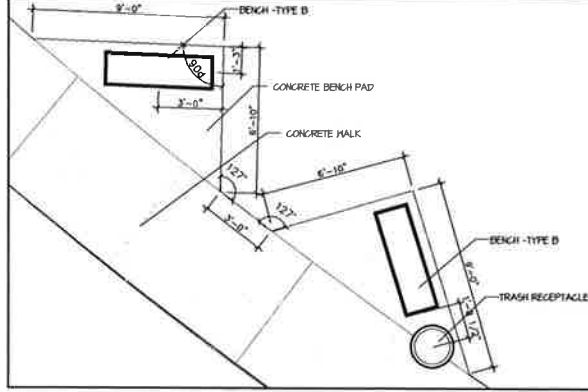

Jc BENCH PAD DETAIL
SCALE: 1/4\"/>

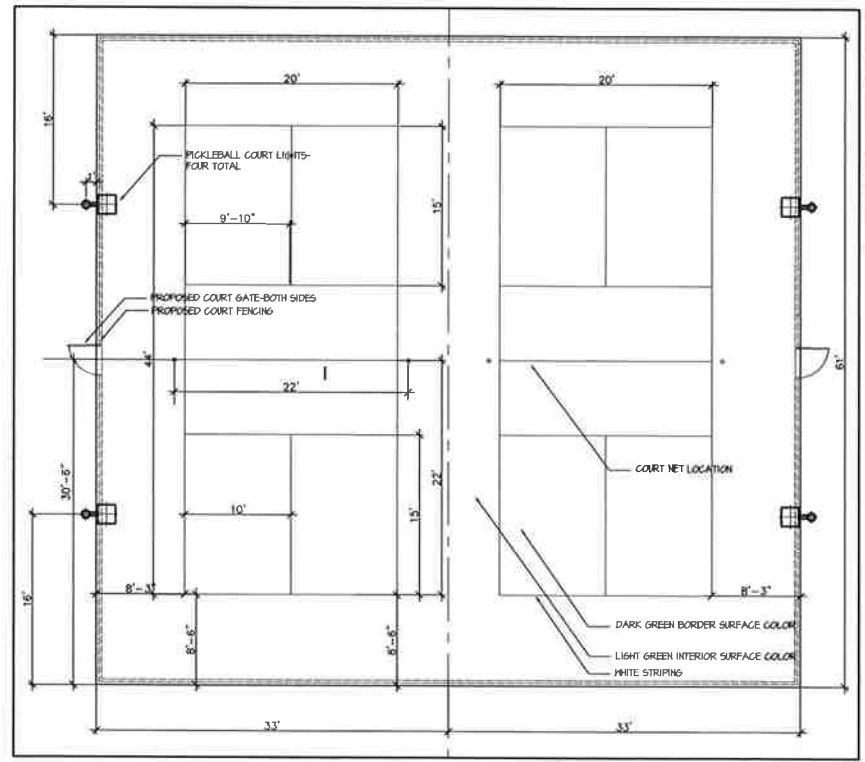

1a PICKLEBALL COURTS
SCALE: 1/8\"/>

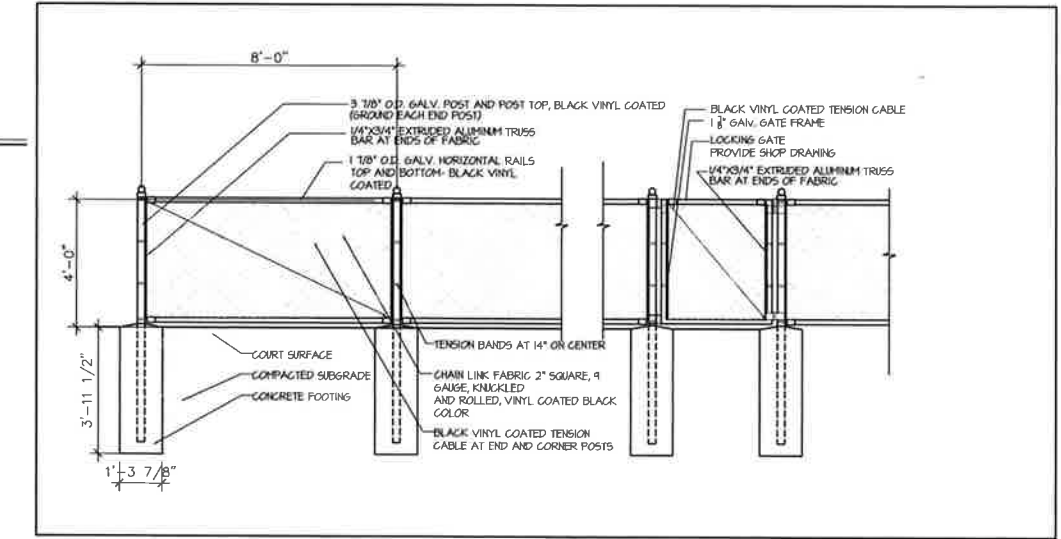

1b PICKLEBALL COURT FENCING
SCALE: 3/8\"/>

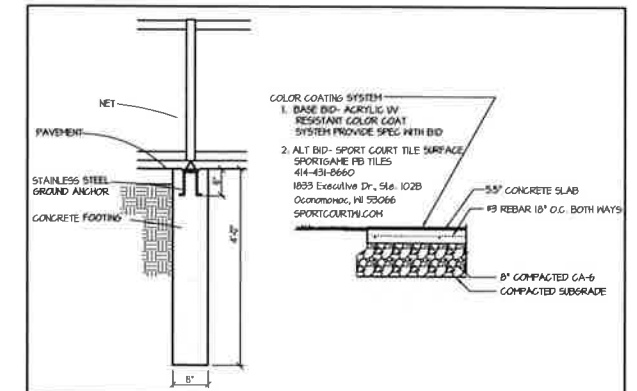

1c PICKLEBALL CT. PVT SECTION/NET
SCALE: 1/2\"/>

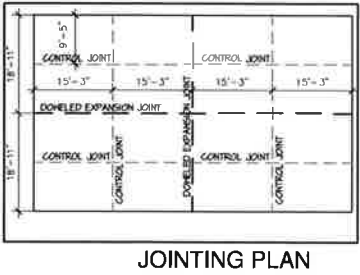

JOINTING PLAN

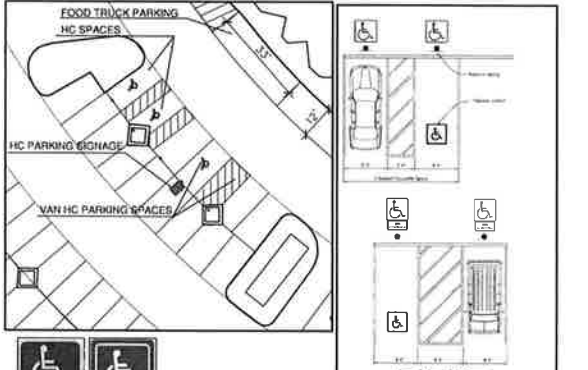

M HANDICAPPED PARKING
SCALE: 1\"/>

HC PARKING SIGNAGE

ISSUE DATE: 02-21-2024

REVISIONS	DATE	BY	DESCRIPTION
001	02/21/2024	City Comments	



Arcadia Exterior Amenities
7000 Vista Drive
West Des Moines, IA 50266



4601 Westown Parkway, Suite 208
West Des Moines, Iowa 50266
515.273.3020

JOB NO: 1923292-00 PROJECT: 50
DRAWN: TJS CHECKED: --
SITE DETAILS

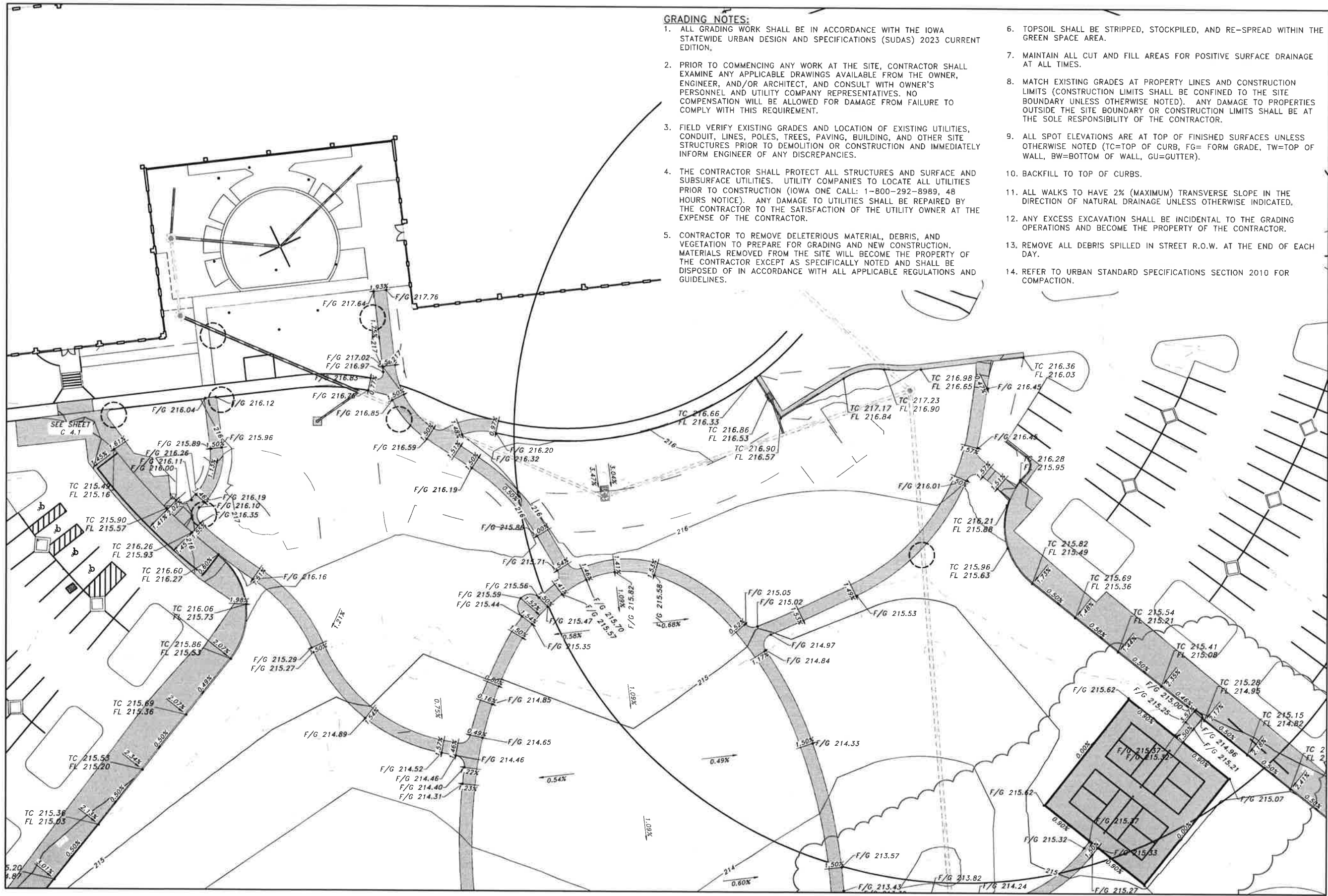

GRADING NOTES:

1. ALL GRADING WORK SHALL BE IN ACCORDANCE WITH THE IOWA STATEWIDE URBAN DESIGN AND SPECIFICATIONS (SUDAS) 2023 CURRENT EDITION.
2. PRIOR TO COMMENCING ANY WORK AT THE SITE, CONTRACTOR SHALL EXAMINE ANY APPLICABLE DRAWINGS AVAILABLE FROM THE OWNER, ENGINEER, AND/OR ARCHITECT, AND CONSULT WITH OWNER'S PERSONNEL AND UTILITY COMPANY REPRESENTATIVES. NO COMPENSATION WILL BE ALLOWED FOR DAMAGE FROM FAILURE TO COMPLY WITH THIS REQUIREMENT.
3. FIELD VERIFY EXISTING GRADES AND LOCATION OF EXISTING UTILITIES, CONDUIT, LINES, POLES, TREES, PAVING, BUILDING, AND OTHER SITE STRUCTURES PRIOR TO DEMOLITION OR CONSTRUCTION AND IMMEDIATELY INFORM ENGINEER OF ANY DISCREPANCIES.
4. THE CONTRACTOR SHALL PROTECT ALL STRUCTURES AND SURFACE AND SUBSURFACE UTILITIES. UTILITY COMPANIES TO LOCATE ALL UTILITIES PRIOR TO CONSTRUCTION (IOWA ONE CALL: 1-800-292-8989, 48 HOURS NOTICE). ANY DAMAGE TO UTILITIES SHALL BE REPAIRED BY THE CONTRACTOR TO THE SATISFACTION OF THE UTILITY OWNER AT THE EXPENSE OF THE CONTRACTOR.
5. CONTRACTOR TO REMOVE DELETERIOUS MATERIAL, DEBRIS, AND VEGETATION TO PREPARE FOR GRADING AND NEW CONSTRUCTION. MATERIALS REMOVED FROM THE SITE WILL BECOME THE PROPERTY OF THE CONTRACTOR EXCEPT AS SPECIFICALLY NOTED AND SHALL BE DISPOSED OF IN ACCORDANCE WITH ALL APPLICABLE REGULATIONS AND GUIDELINES.
6. TOPSOIL SHALL BE STRIPPED, STOCKPILED, AND RE-SPREAD WITHIN THE GREEN SPACE AREA.
7. MAINTAIN ALL CUT AND FILL AREAS FOR POSITIVE SURFACE DRAINAGE AT ALL TIMES.
8. MATCH EXISTING GRADES AT PROPERTY LINES AND CONSTRUCTION LIMITS (CONSTRUCTION LIMITS SHALL BE CONFINED TO THE SITE BOUNDARY UNLESS OTHERWISE NOTED). ANY DAMAGE TO PROPERTIES OUTSIDE THE SITE BOUNDARY OR CONSTRUCTION LIMITS SHALL BE AT THE SOLE RESPONSIBILITY OF THE CONTRACTOR.
9. ALL SPOT ELEVATIONS ARE AT TOP OF FINISHED SURFACES UNLESS OTHERWISE NOTED (TC=TOP OF CURB, FG= FORM GRADE, TW=TOP OF WALL, BW=BOTTOM OF WALL, GU=GUTTER).
10. BACKFILL TO TOP OF CURBS.
11. ALL WALKS TO HAVE 2% (MAXIMUM) TRANSVERSE SLOPE IN THE DIRECTION OF NATURAL DRAINAGE UNLESS OTHERWISE INDICATED.
12. ANY EXCESS EXCAVATION SHALL BE INCIDENTAL TO THE GRADING OPERATIONS AND BECOME THE PROPERTY OF THE CONTRACTOR.
13. REMOVE ALL DEBRIS SPILLED IN STREET R.O.W. AT THE END OF EACH DAY.
14. REFER TO URBAN STANDARD SPECIFICATIONS SECTION 2010 FOR COMPACTION.

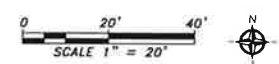

GRADING IMPORT CALCULATION
 4554 CY IMPORT
 1244 CY FILL - TIN TO TIN 1.3 SHRINK
 3500 CY PAVEMENT REMOVAL NOT REPLACED
 190 CY NEW SIDEWALK.



Arcadia Exterior Amenities
 7000 Vista Drive
 West Des Moines, IA 50266



4601 Westown Parkway, Suite 208
 West Des Moines, Iowa 50266
 515 273 3020

JOB NO: 231665 PROJ MGR: GDC
 DRAWN: DEL CHECKED:
 GRADING

2024-02-16- Construction Documents

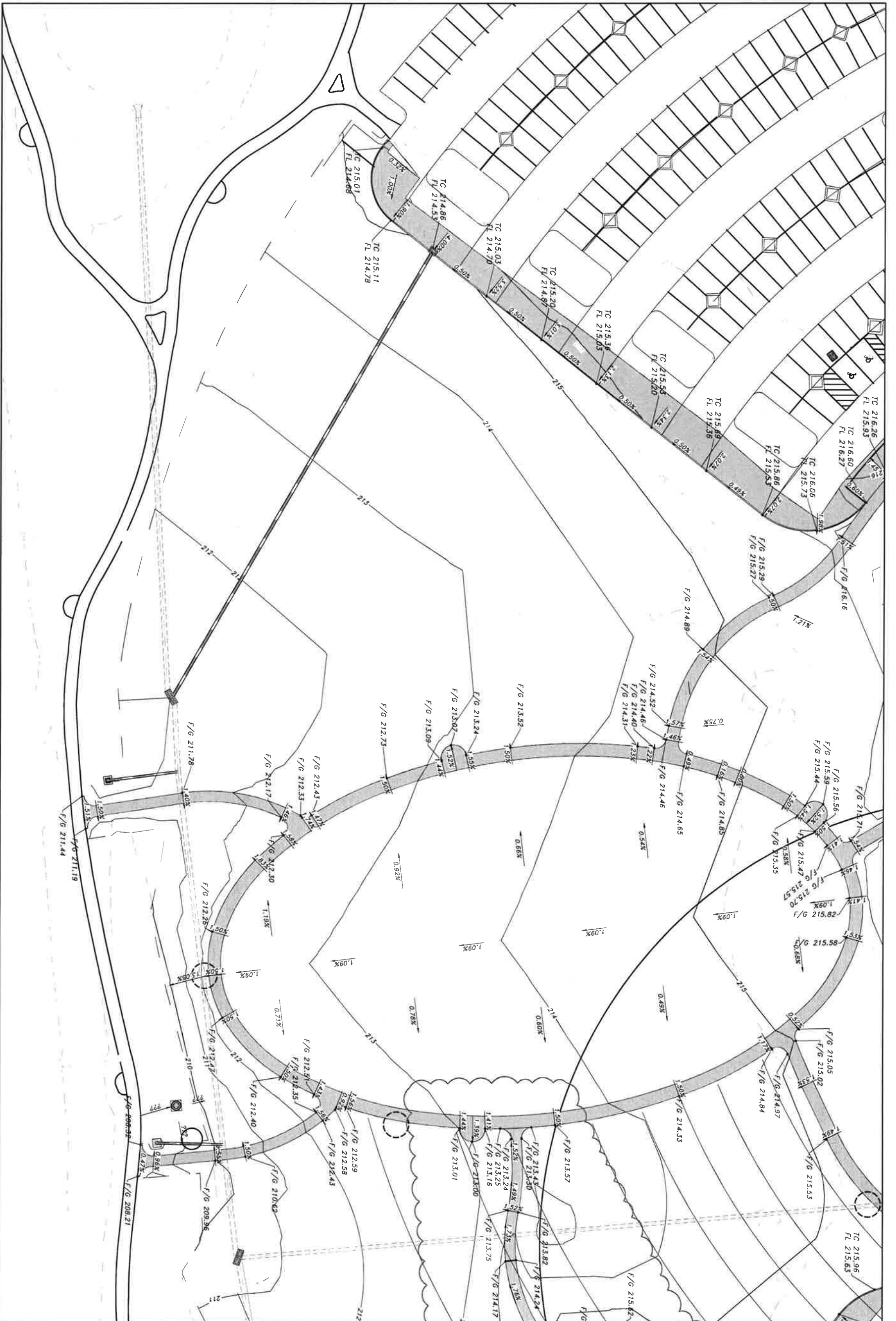

2024-02-16- Construction Documents

C1.1

JOHN ZIMMERMAN CONSULTING GROUP
 DRAWN BY: DIERCE
 CHECKED BY: DIERCE
 DESIGNED BY: DIERCE

401 Westview Parkway, Suite 208
 West Des Moines, IA 50396
 Phone: 515.973.3000



Arcadia Exterior Amenities
 7000 Vista Drive
 West Des Moines, IA 50266



ISSUE DATE:	02/17/2024
BY:	JOHN ZIMMERMAN
DATE:	02/17/24 (24) 02/17/24



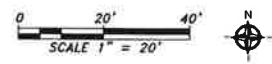
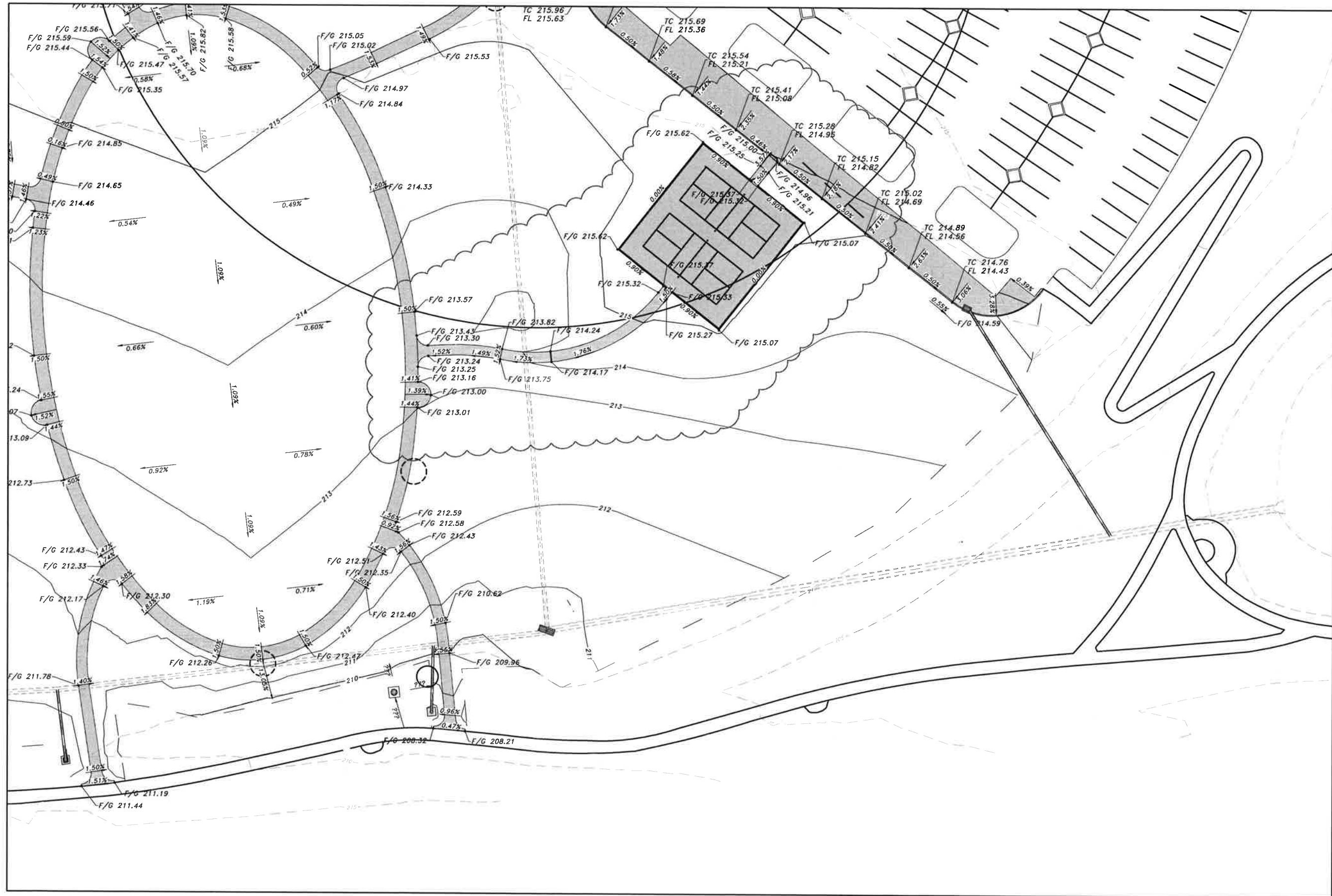

2024-02-16- Construction Documents



ISSUE DATE:	02/17/2024
HYDROLOGIST:	DAVID L. CRANE, P.E.
PROJECT:	ARCADIA EXTERIOR AMENITIES
DATE:	02/17/24
SCALE:	AS SHOWN
PROJECT NO.:	231965
DRAWN BY:	MS
CHECKED BY:	MS
DATE:	02/17/24



Arcadia Exterior Amenities
 7000 Vista Drive
 West Des Moines, IA 50266



4601 Westown Parkway, Suite 208
 West Des Moines, Iowa 50266
 515 273 3020

JOB NO. 231965	PROJECT: ARCADIA EXTERIOR AMENITIES
DRAWN: MS	PROJ. MGR: GSC
DATE: 02/17/24	CHECKED: MS
SCALE: AS SHOWN	DISCIPLINE: GRADING

C 1.2

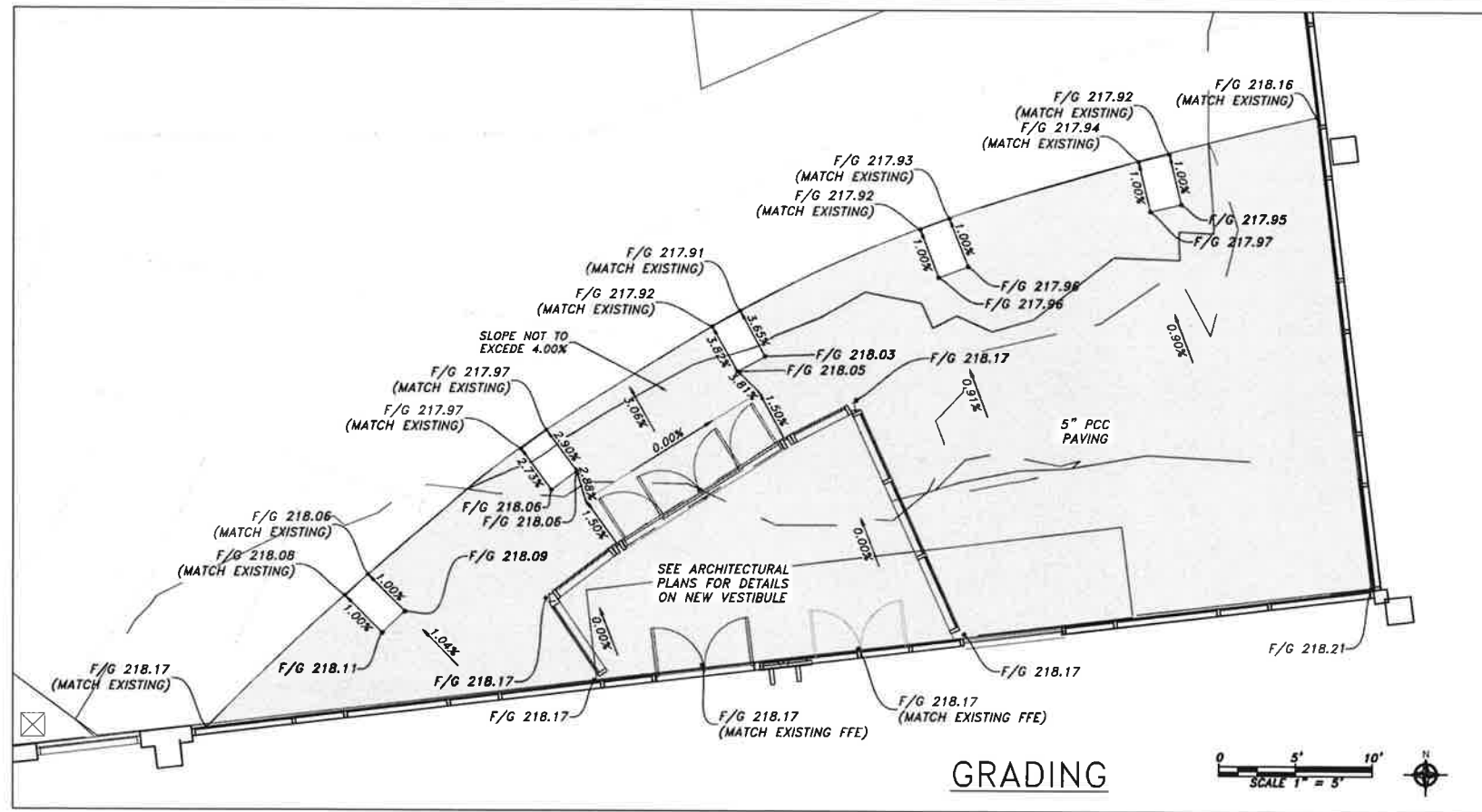
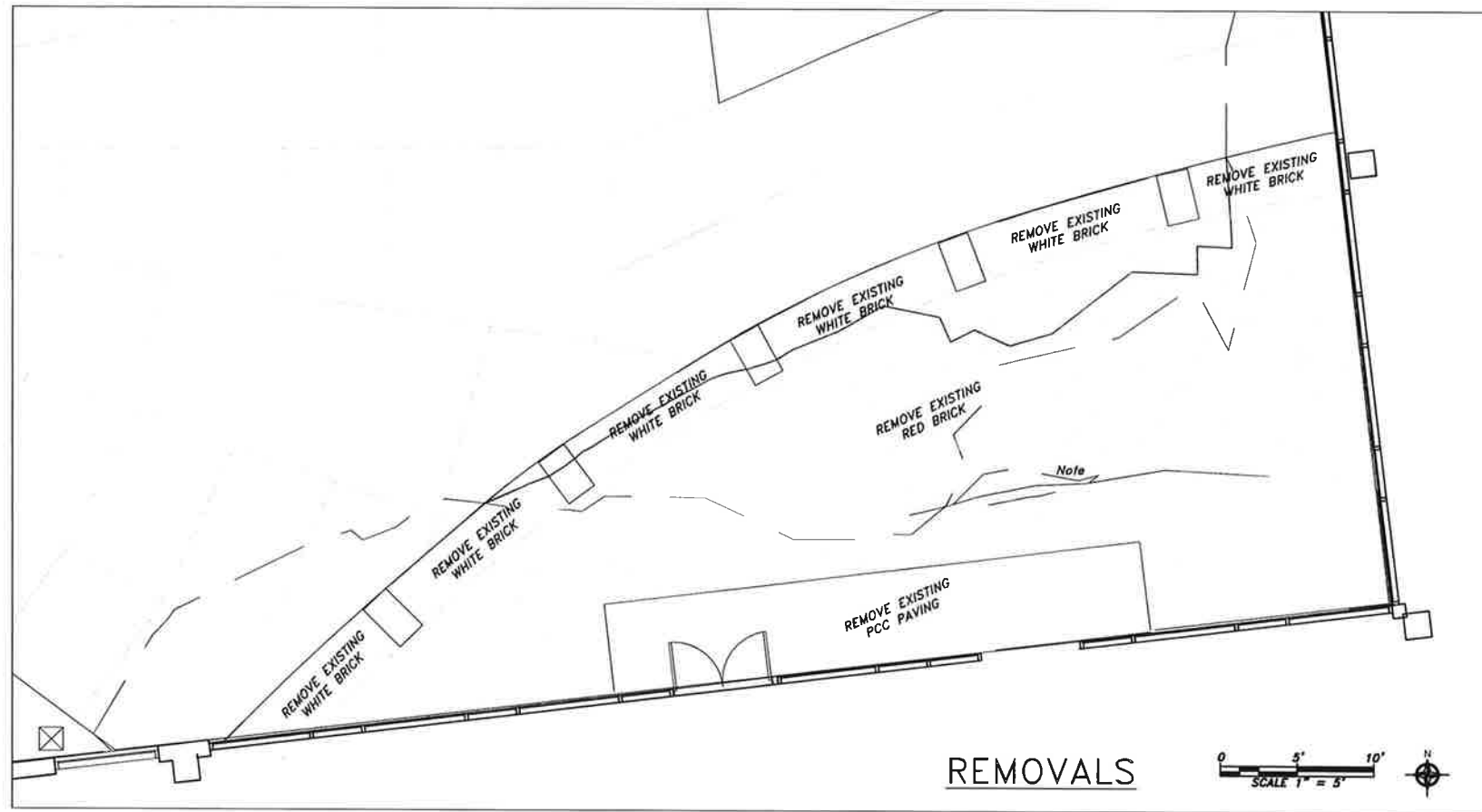

NOTES:

1. NO ACCESS TO THE BUILDING BY TENANTS WILL BE ALLOWED DURING CONSTRUCTION OF THIS AREA. CONTRACTOR SHALL COORDINATE WITH THE OWNER AND CITY OF WEST DES MOINES BUILDING AND FIRE DEPARTMENT FOR ALTERNATIVE BUILDING ACCESS/EGRESS ROUTES
2. ALL MATERIALS REMOVED FROM THE SITE WILL BECOME THE PROPERTY OF THE CONTRACTOR EXCEPT AS SPECIFICALLY NOTED AND SHALL BE DISPOSED OF IN ACCORDANCE WITH ALL APPLICABLE REGULATIONS AND GUIDELINES.



ISSUE DATE:	02-17-2024
REVISIONS:	
	01/27/24 City Approval 1



2024-02-16- Construction Documents

Arcadia Exterior Amenities
7000 Vista Drive
West Des Moines, IA 50266



4601 Westown Parkway, Suite 208
West Des Moines, Iowa 50266
515.276.3020

JOB NO: 231885 PROJ. NO.: GDC
DRAWN: DEL CHECKED: -
NORTH VESTIBULE
GRADING AND REMOVALS

C 1.3

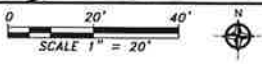
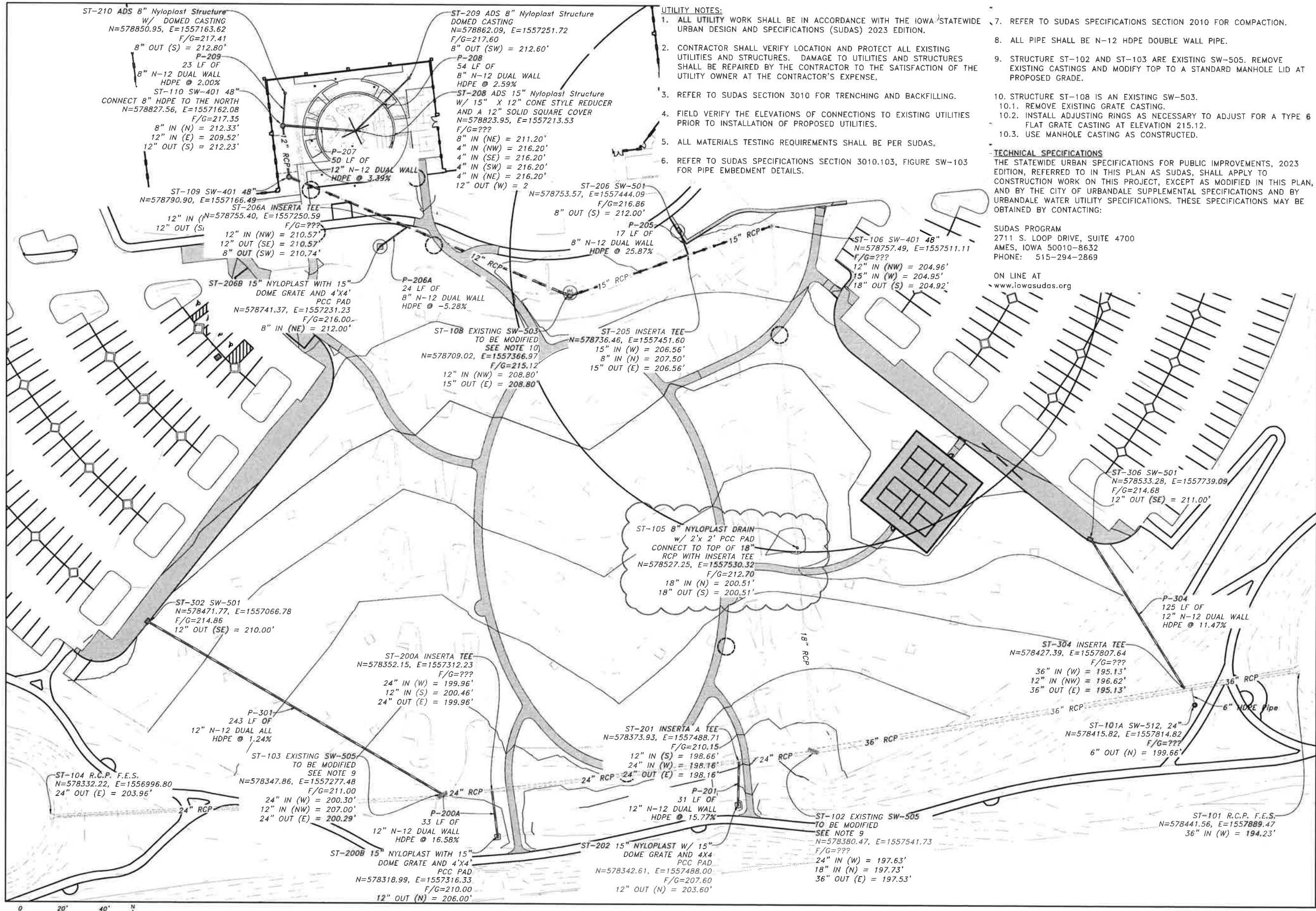

Arcadia Exterior Amenities
 7000 Vista Drive
 West Des Moines, IA 50266



4601 Westown Parkway, Suite 208
 West Des Moines, Iowa 50266
 515.273.3020

JOB NO: 2318895 PROJ MGR: GDC
 DRAWN: DEL CHECKED: -
 Storm Sewer

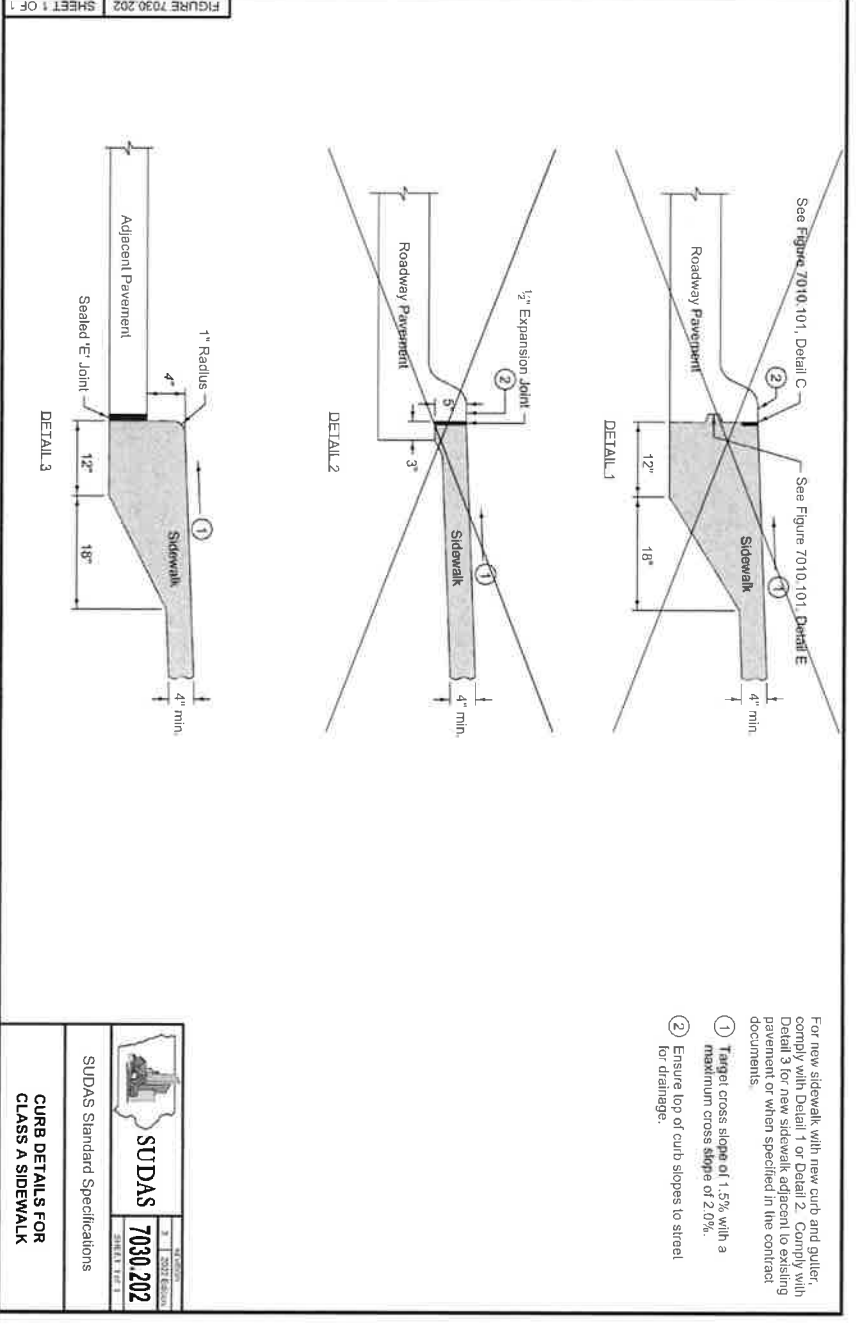
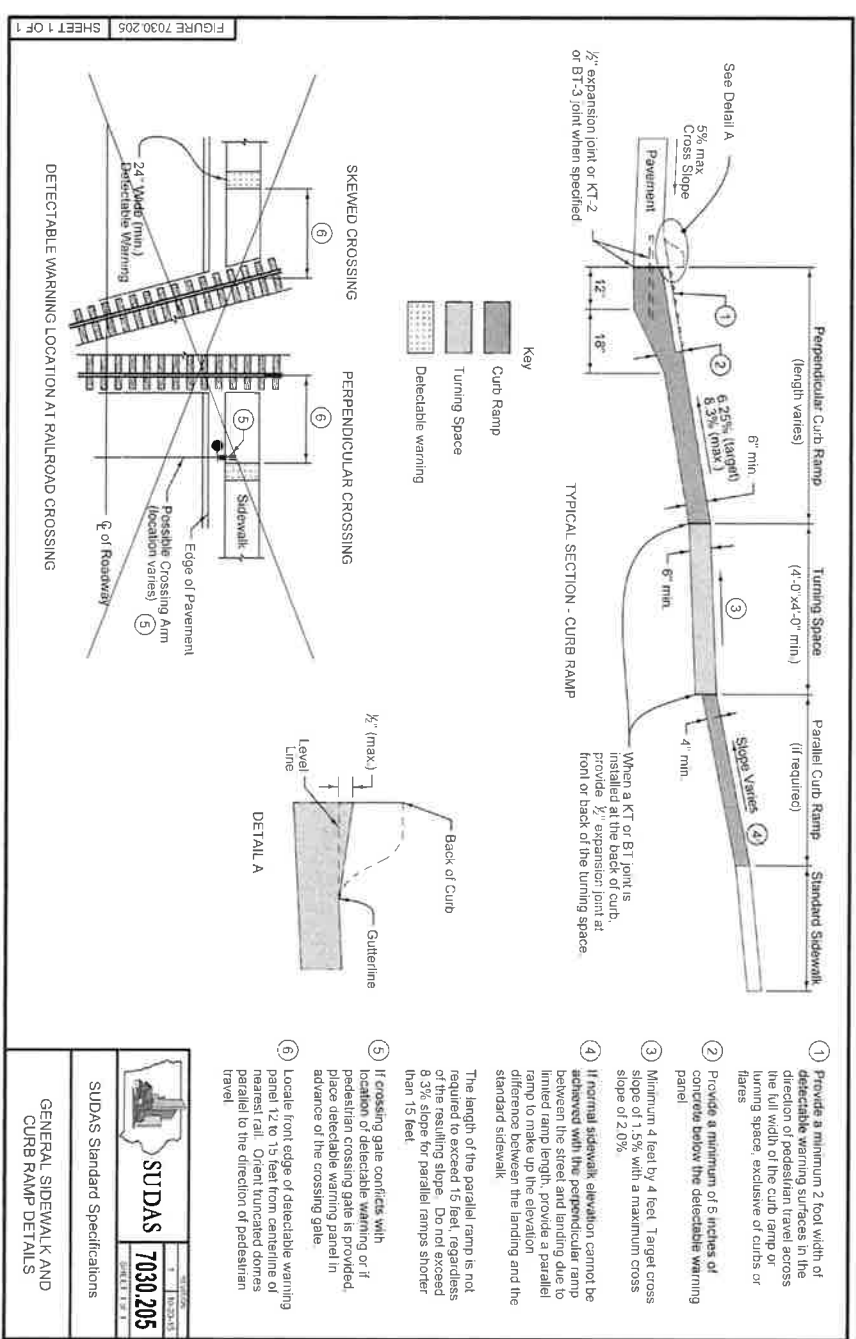
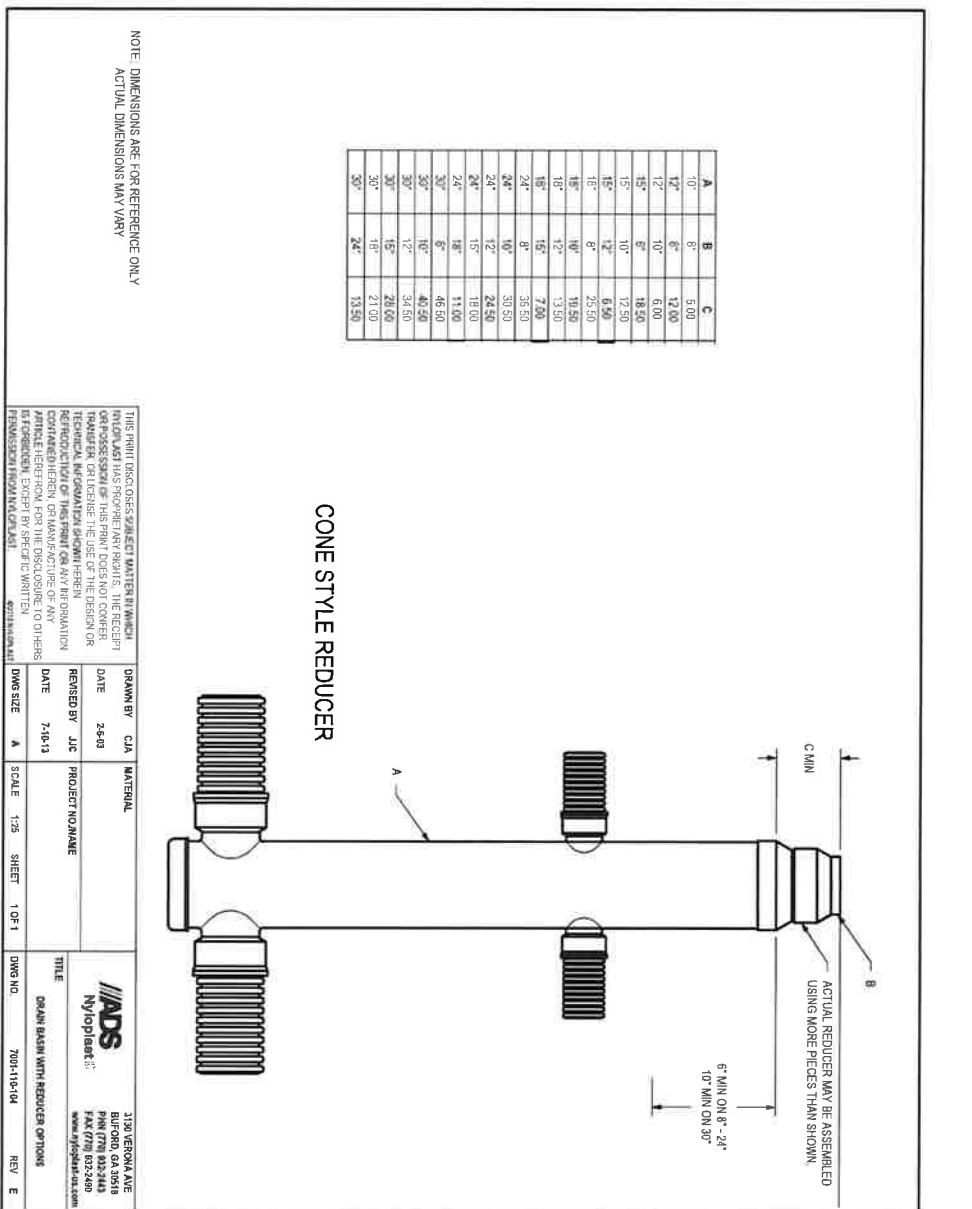
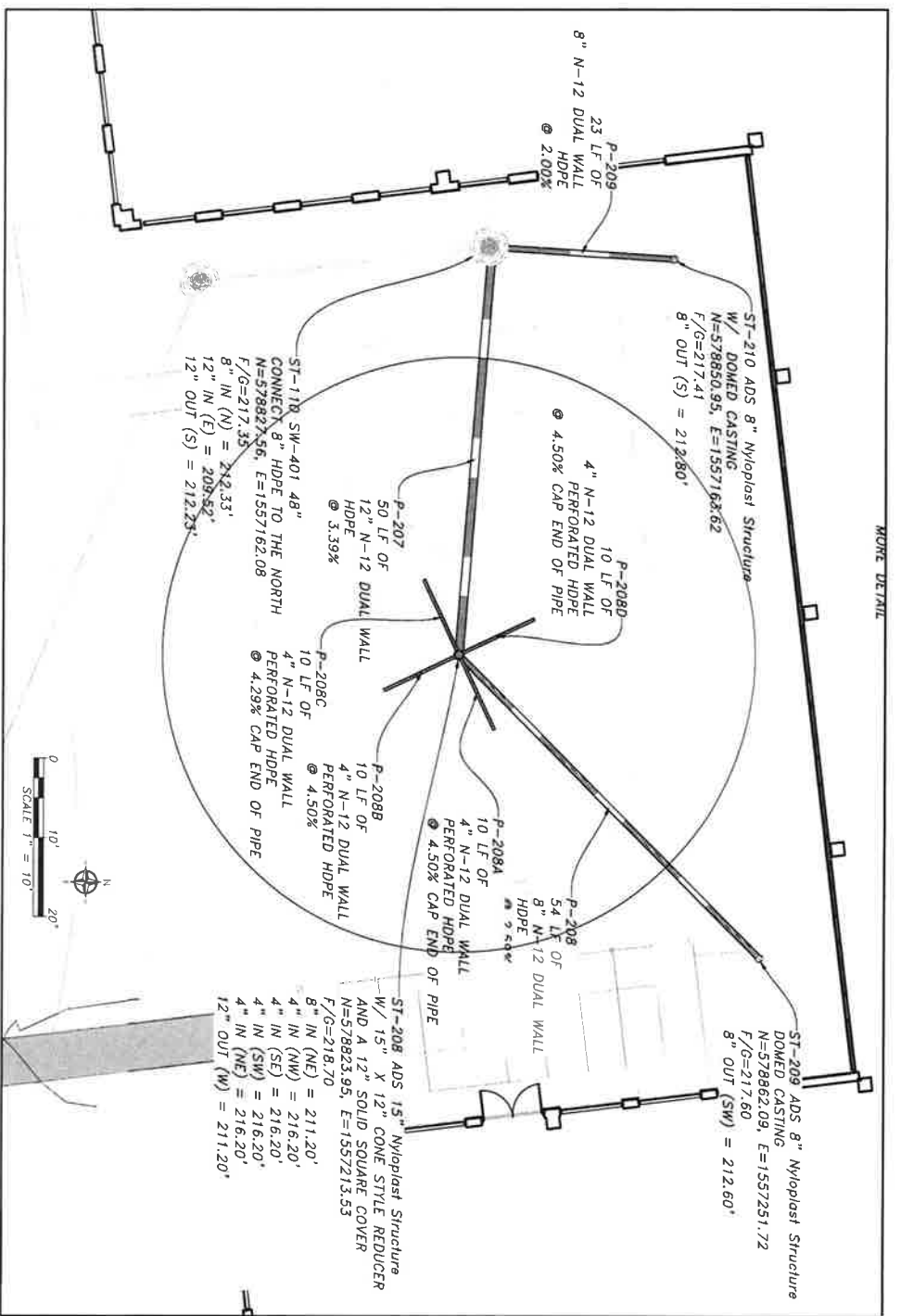

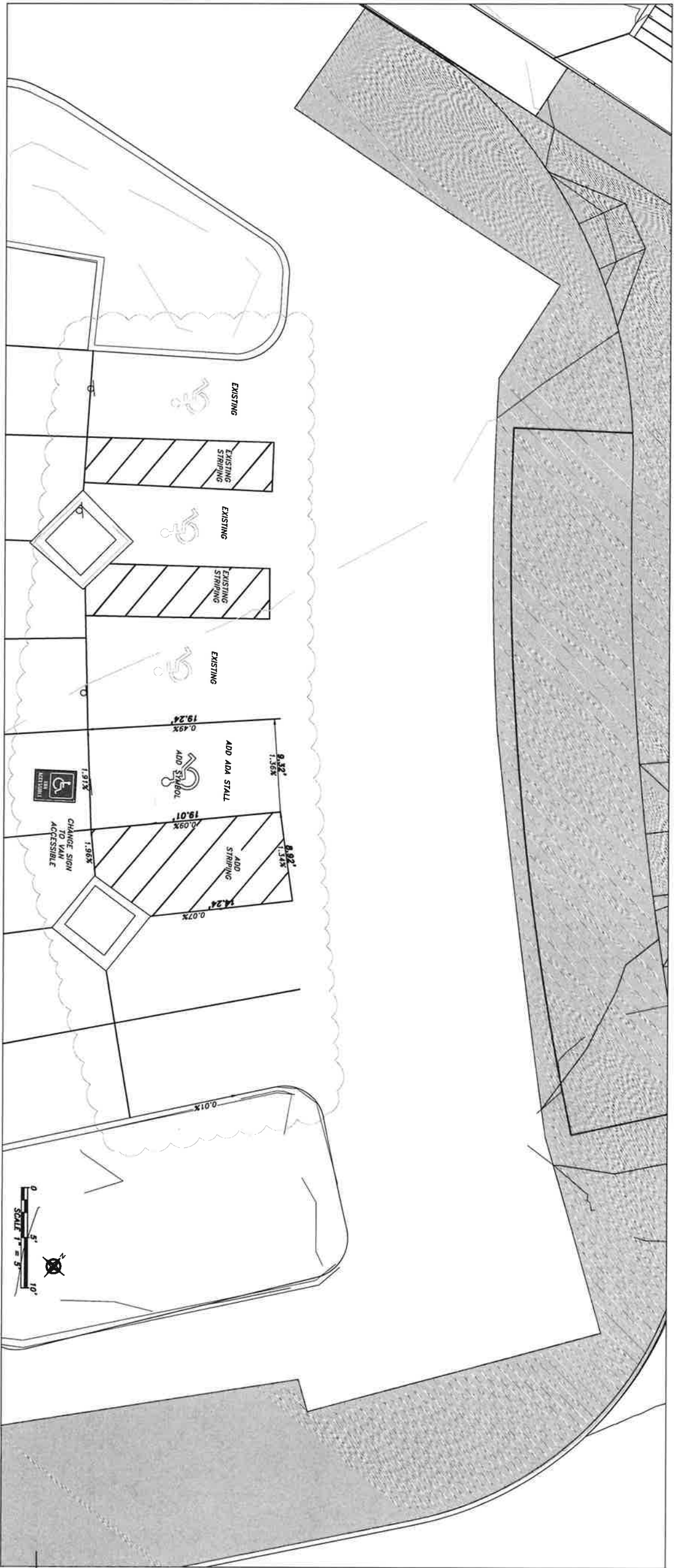
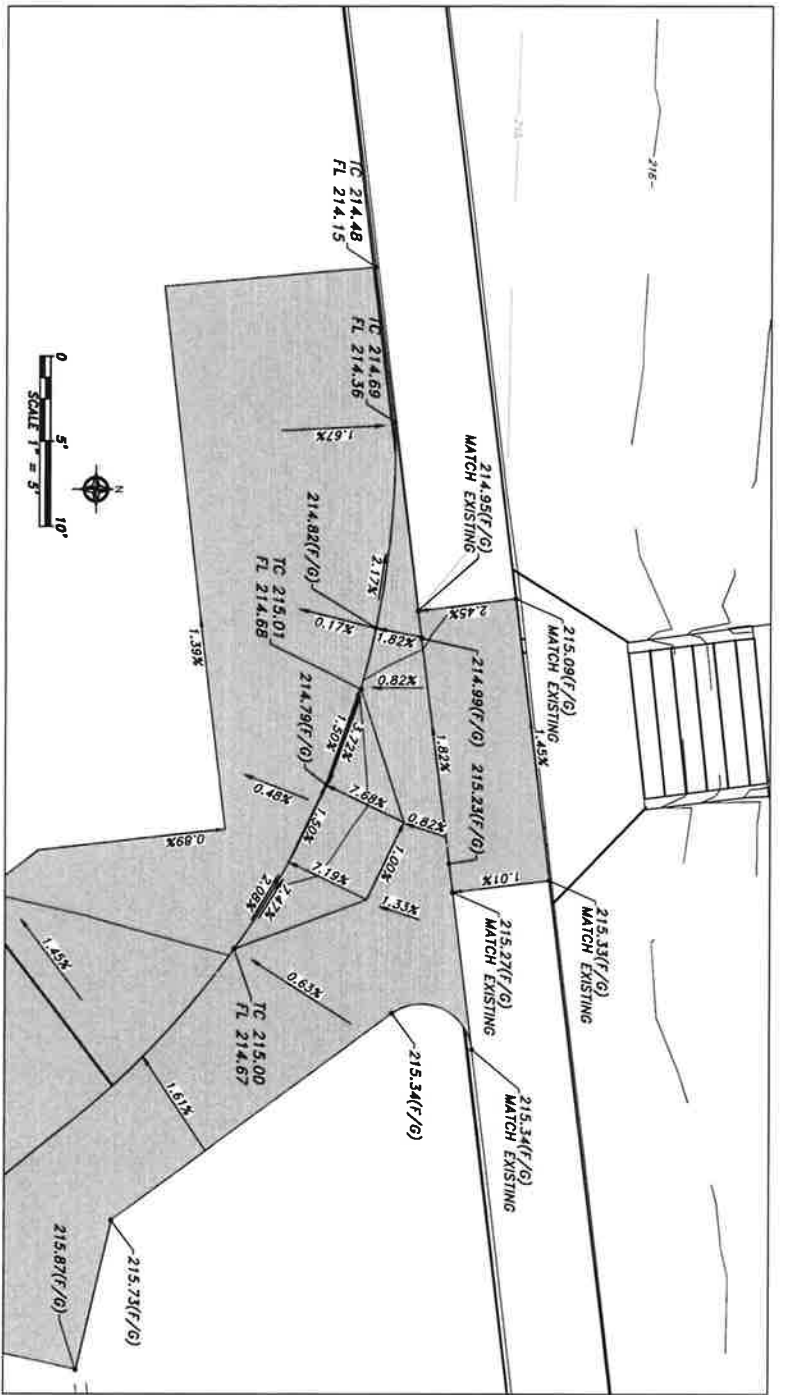

2024-02-16- Construction Documents

C 3.1

DESIGN: [Blank]
 CHECKED: [Blank]

DATE: [Blank]

4601 Westown Parkway, Suite 208
 West Des Moines, IA 50325
 (515) 273-3000



Arcadia Exterior Amenities
 7000 Vista Drive
 West Des Moines, IA 50266



ISSUE DATE:	02-17-2024
REVISIONS	
	03/27/24 [City comments 1]

